

NEXUS™ 140

Internal Recycling Unit

USER INSTRUCTIONS

IMPORTANT NOTE:- ENSURE ALL RELEVANT PERSONNEL READ THESE INSTRUCTIONS PRIOR TO OPERATION

1.1. To open the door, lift both latches (Diagram A).

1.2. When both latches are released the door can be lowered until it reaches its rest position (approximately 60° angle from its closed position).

N.B. If a lock is fitted, the two latches are not included. The door can be opened by turning the key clockwise before lowering the door.

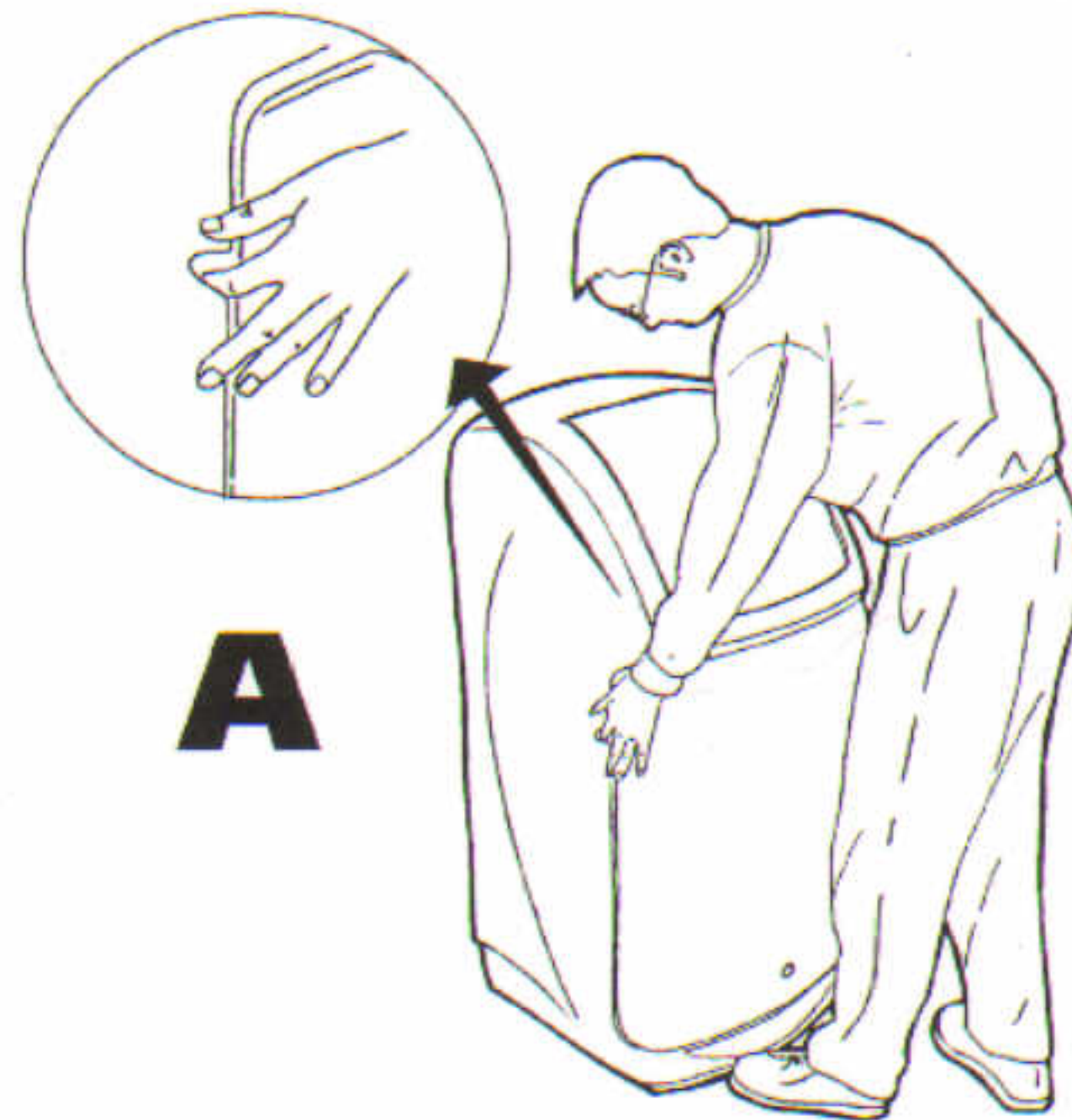

A

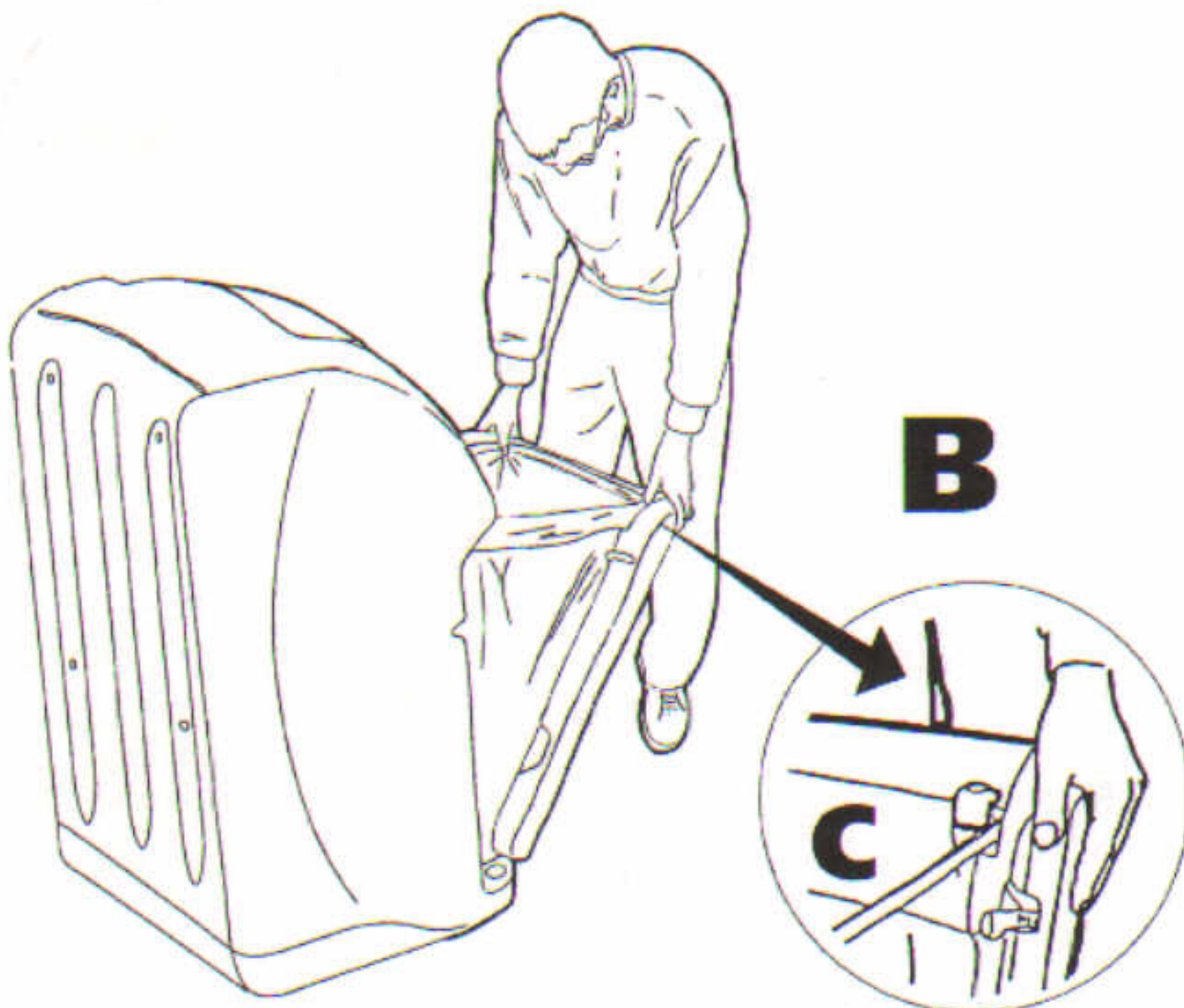

B

1.3. Place and open sack between the steel sack band and wrap it around the front rubber grips located on both top corners of the door (Diagram C). Raise the steel sack band to a slight angle and wrap the sack around it before returning the band to its original position.

1.4. To close the bin simply push the top edge of the door fully home, ensuring both latches (where fitted) are engaged. Where a lock is fitted turn the key anti clockwise to lock the door.



D

2. REMOVAL OF CONTENTS

The door is opened following steps 1.1. and 1.2. above. When the door is resting in the open position (Diagram D) the sack can be loosened by raising the sack band slightly. The sack can be released from under the band. The band can be lifted 90° (allowing the full sack to be easily removed from the bin).

IMPORTANT

Please be mindful, frequent emptying is recommended to avoid accumulation of excessive weight.

However, from this position, for heavy loads, it is recommended the door is totally removed. This is achieved by pushing the door back towards closure by approximately 20 degrees. From this position the door can be lifted upwards and out of its location (Diagram E). The full waste sack can then be pulled forward and out of the bin.

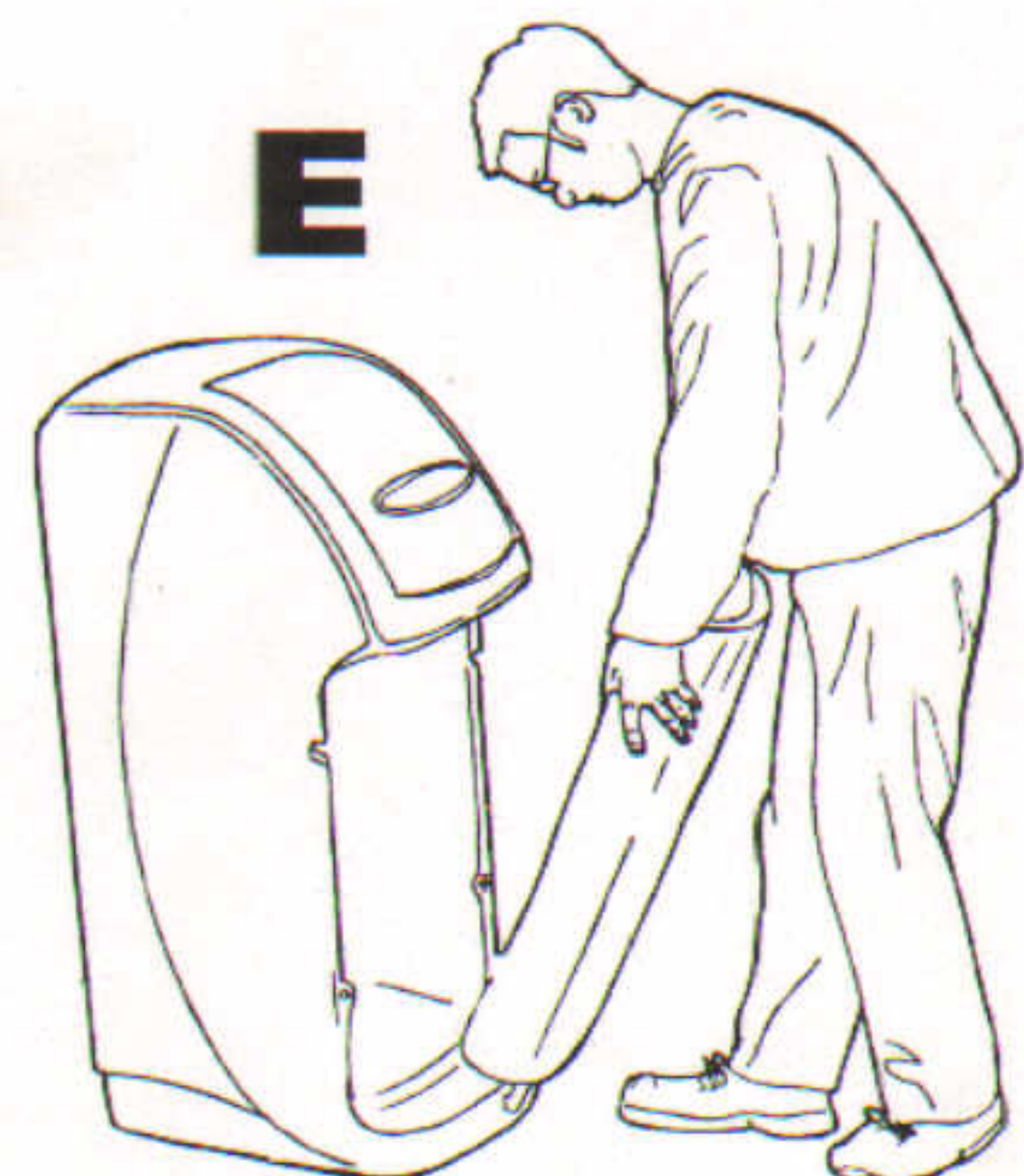

E

SIGN KIT ASSEMBLY INSTRUCTIONS

1. INTEGRAL POST MOUNTED SIGN

- 1.1 Place chosen A4 poster and grey infill into the rigid clear wallet (diagram 1).
- 1.2 Slide the rigid wallet into the slots on each tube ensuring the hook feature of the wallet rests on the base of the slot in the tube (diagram 2). When the wallet is fully held by the tubes, push the two caps provided into the top of the tubes.
- 1.3 Offer the assembled sign to the back of the bin and align the location holes in the tube with the appropriate location points in the rear of the bin (diagram 3). Fasten in position using the screws, washers and allen key provided.
- 1.4 The A4 poster can be changed by removing the caps on the top of the tubes and gently pushing the tubes to the side so that the rigid wallet can be removed.

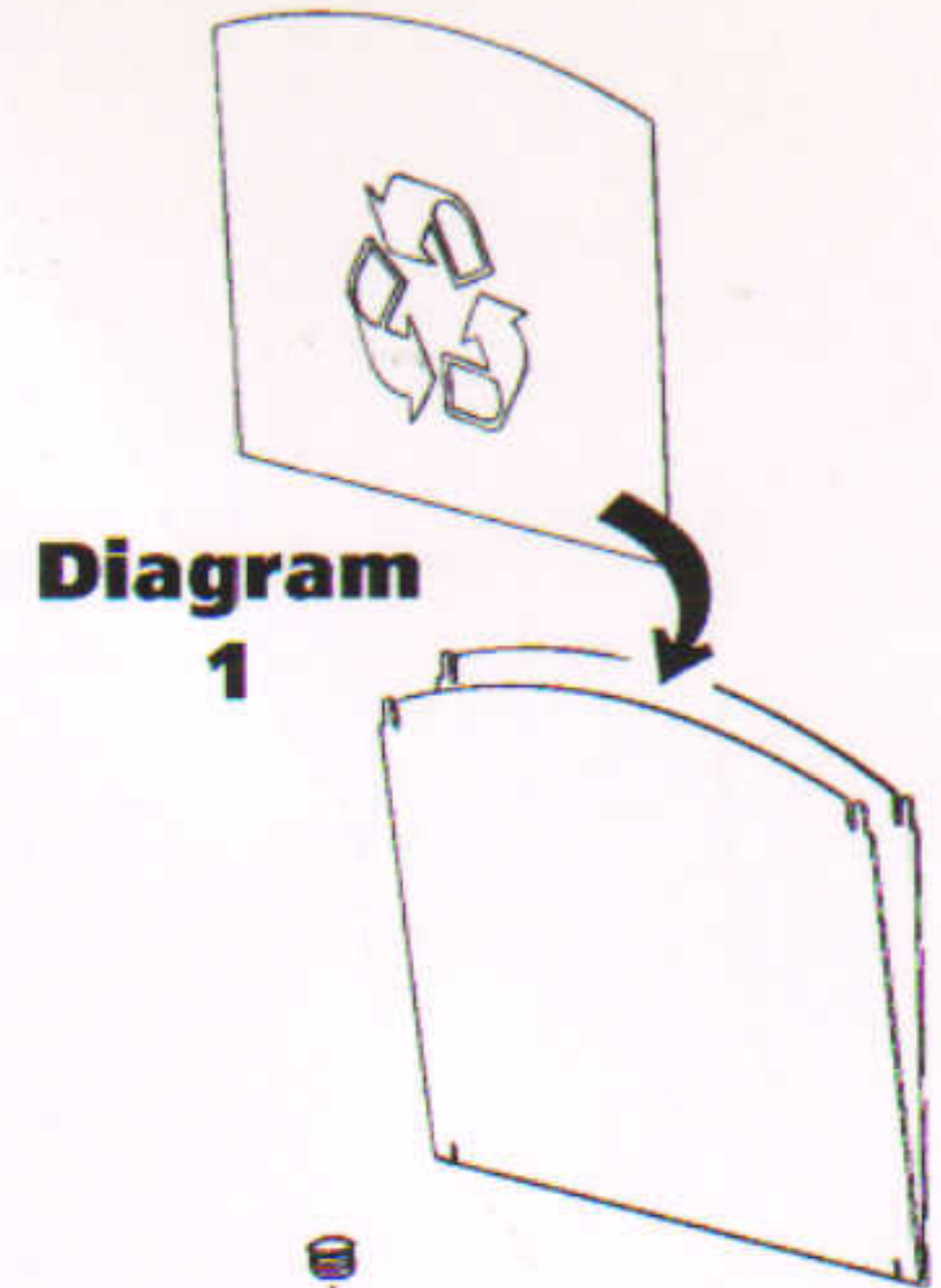

Diagram 2

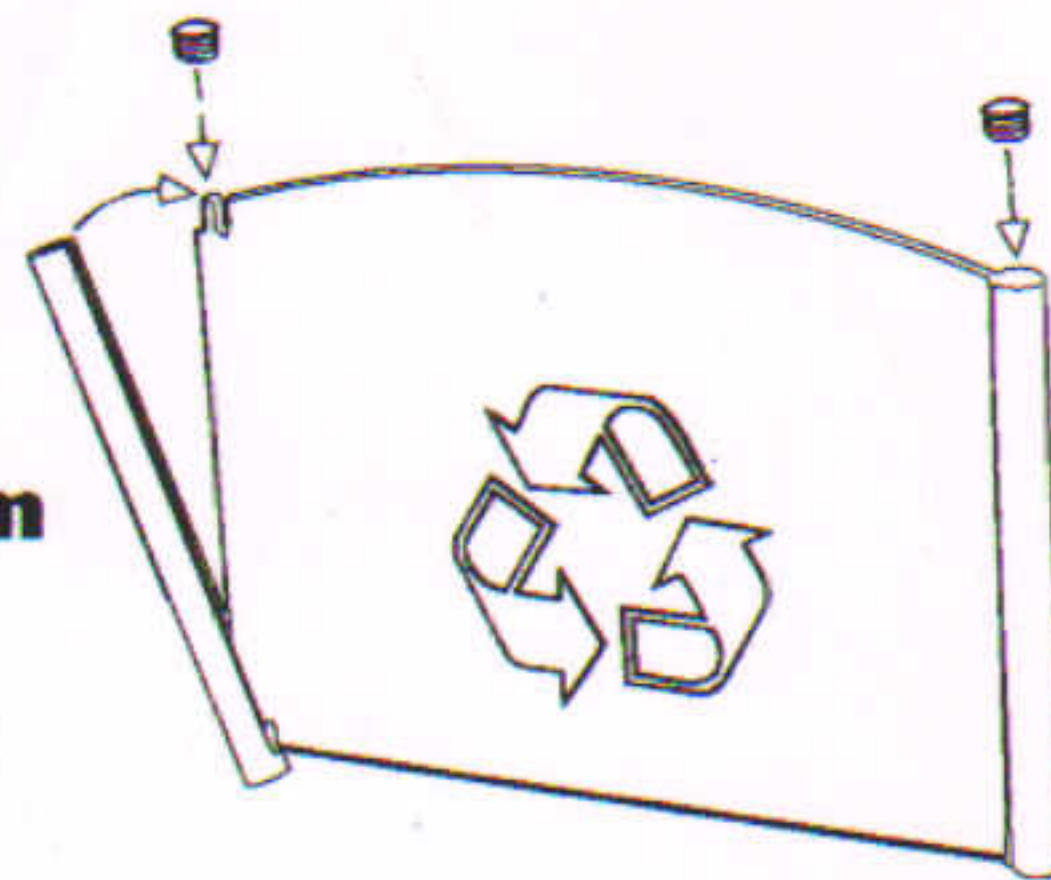

Diagram 3

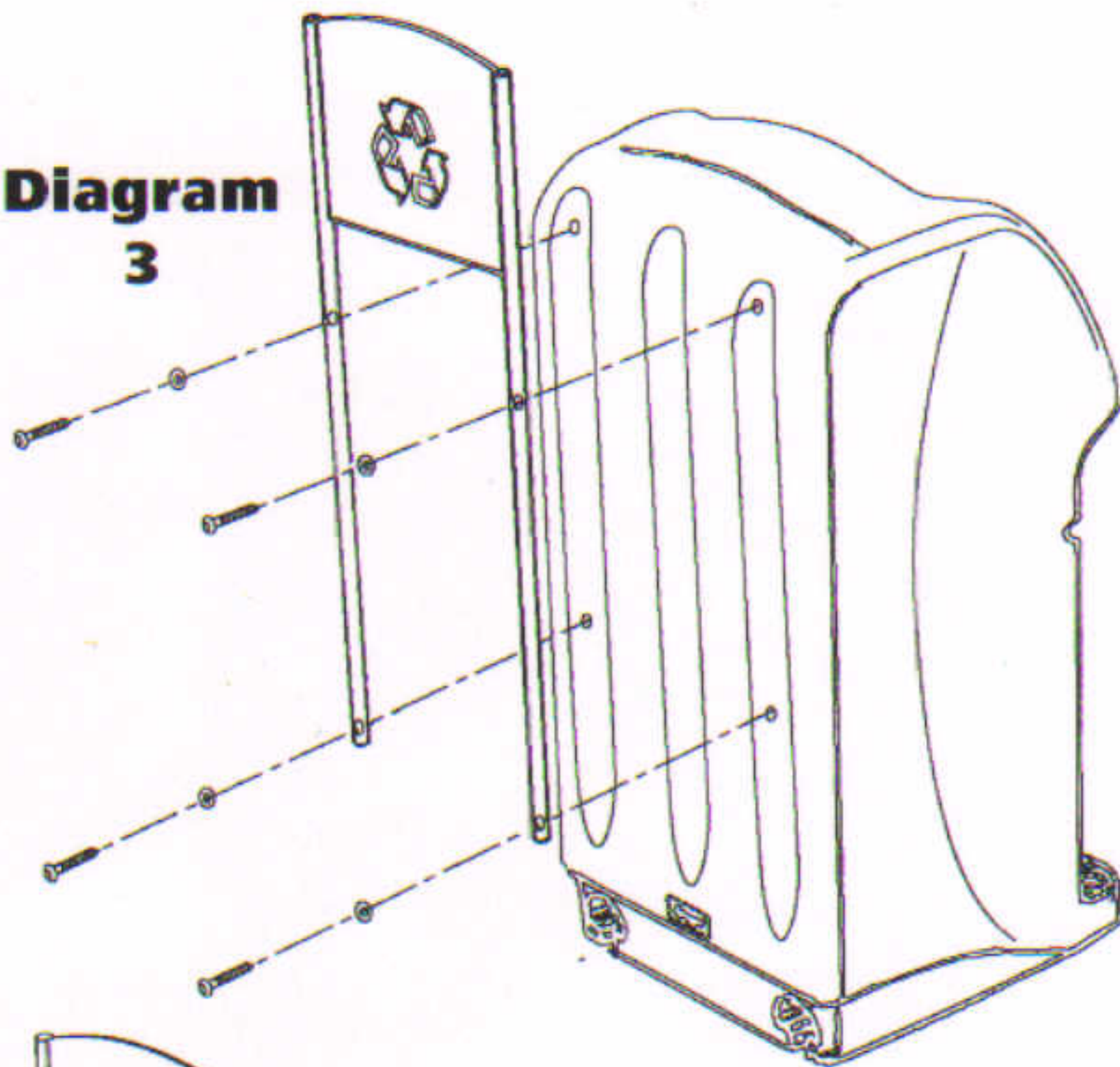
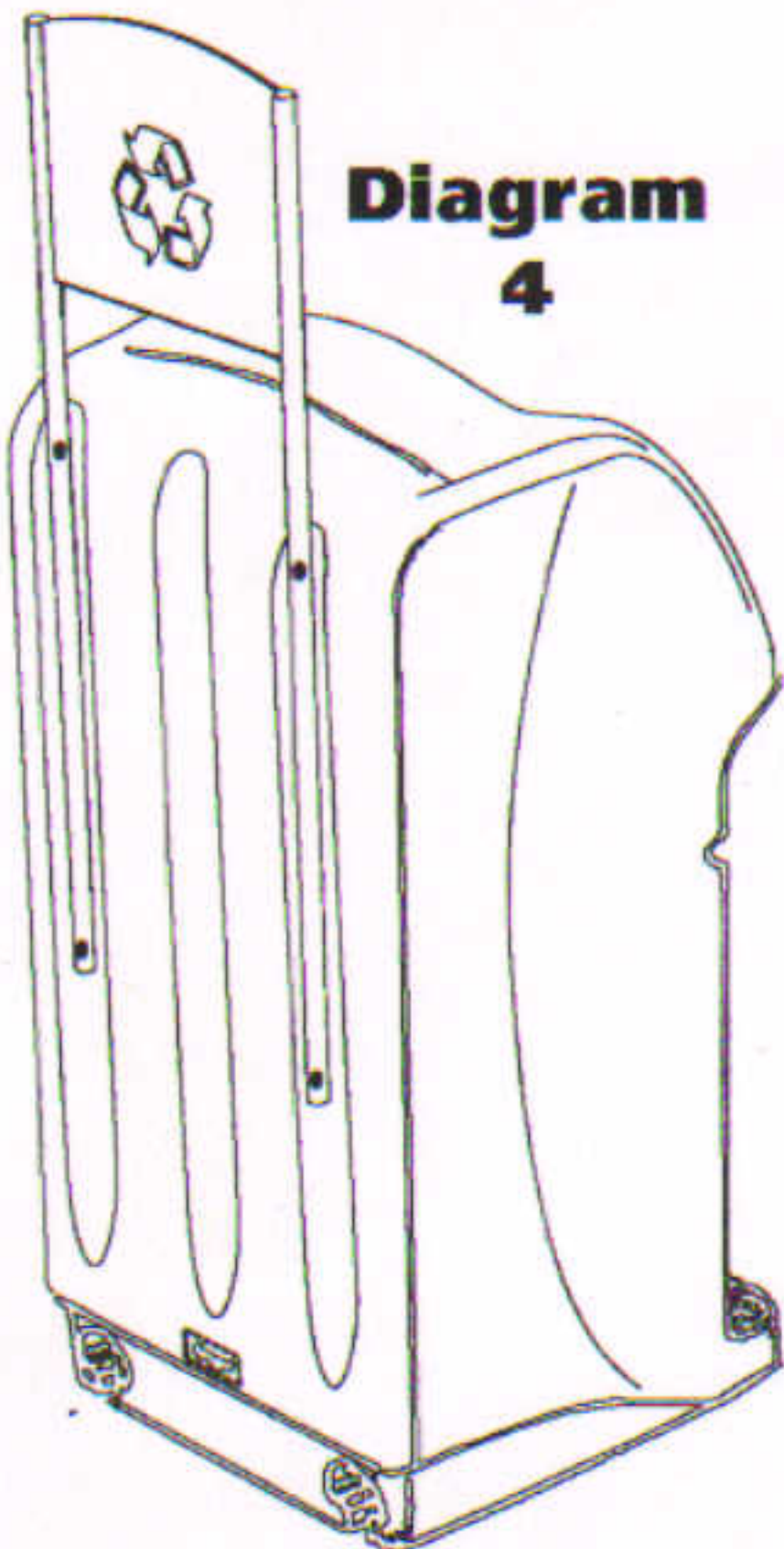

Diagram 4



2 WALL MOUNTED SIGN

- 2.1 Place the chosen A4 poster and grey infill into the rigid clear wallet (diagram 1).
- 2.2 Slide the slotted edge of the tube onto each side of the wallet, (diagram 2) so that the hook feature on the wallet rests at the base of the slots on the tube.
- 2.3 When the wallet is fully held by the tubes push the two caps provided into the top of the tubes while holding the base in place (diagram 5).

- 2.4 Choose the appropriate position for the sign, noting the height of the locating holes on the rear of the tubes.
- 2.5 Mark the wall at the fixing positions ensuring they are level and 350mm apart.
- 2.6 For safety, check for electrics and water before drilling.
- 2.7 Drill wall with a 5mm drill bit at the marked holes 350mm apart.
- 2.8 Insert wall plugs ensuring they are flush with the wall surface.
- 2.9 Using a hexagonal head screwdriver insert the screw into the wall leaving the head 4mm proud of the wall.
- 2.10 Hang the sign onto the screw heads using the location holes in the tubes (diagram 5).

Diagram 5

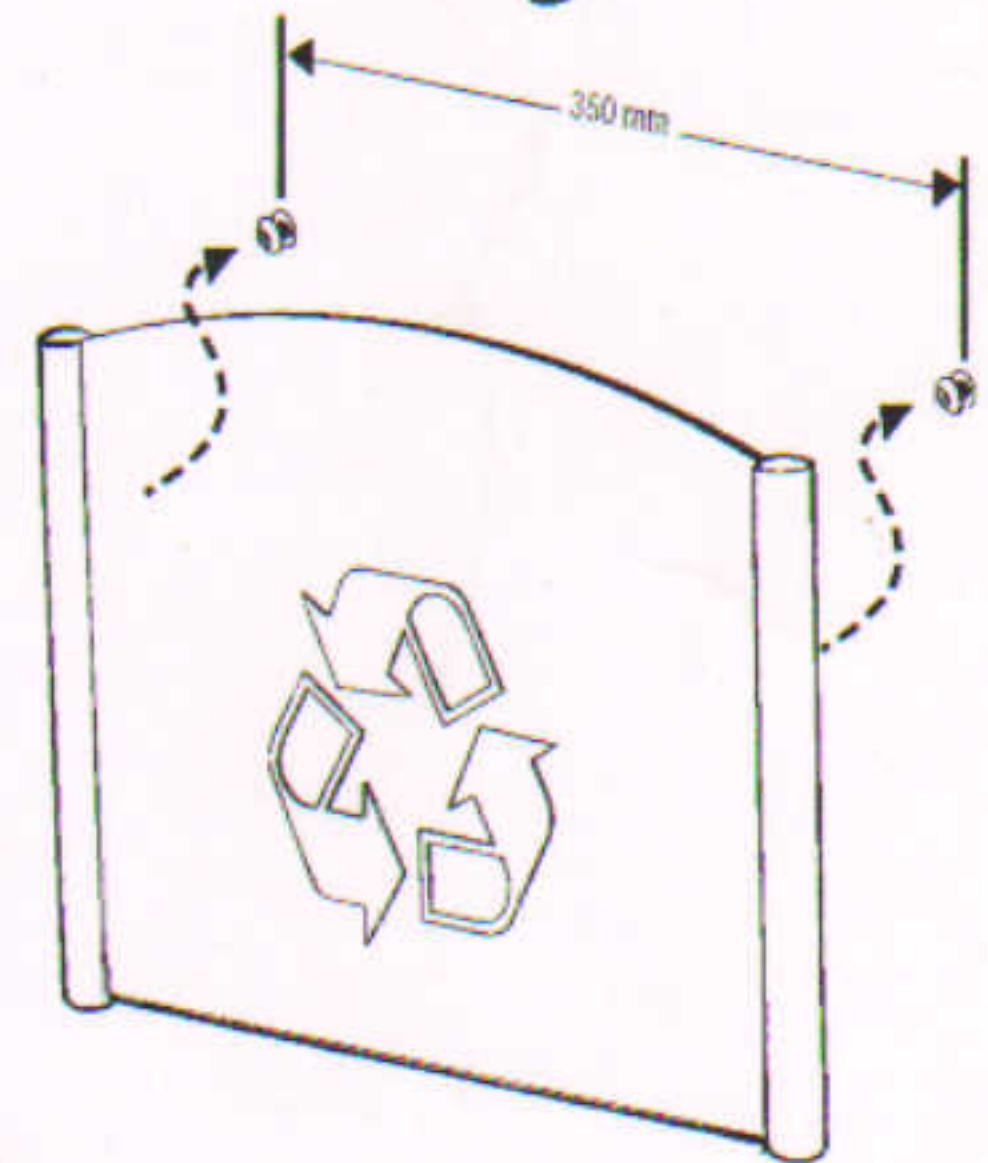

■ A planned maintenance schedule of regular inspection is recommended, replacing components as necessary.

■ Replacement components are available direct from GLASDON.

■ GLASDON cannot be held responsible for claims arising from incorrect installation, unauthorised modifications or misuse of the product.

 **Glasdon** AND NEXUS™ ARE TRADEMARKS OR REGISTERED TRADEMARKS OF GLASDON GROUP OR ITS SUBSIDIARIES IN THE U.K. AND OTHER COUNTRIES



Glasdon U.K. Limited

Preston New Road
BLACKPOOL
Lancashire FY4 4UL

Tel: 01253 600410

Fax: 01253 792558

e-mail: sales@glasdon-uk.co.uk

web: www.glasdon.com