

Nexus[®] Evolution

OPERATOR & INSTALLATION INSTRUCTIONS

IMPORTANT NOTE: ENSURE THAT ALL RELEVANT PERSONNEL READ THESE INSTRUCTIONS PRIOR TO USE

Aperture Lid Operation

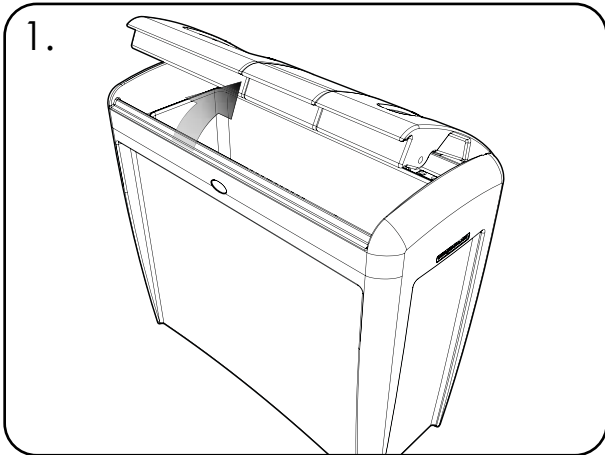

Using the finger lip at the front of the aperture panels lift the lid upwards.

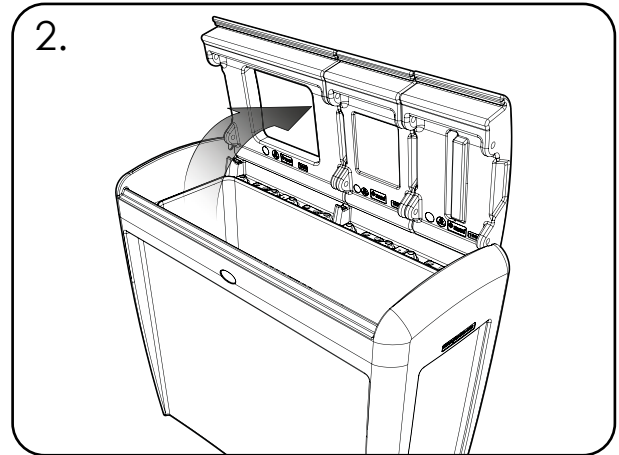

Open the lid to 90 degrees by pushing past the bump feature until the lid rests in an upright position. To close the lid pull the front down firmly to override the bump feature.

Sack Retention Operation

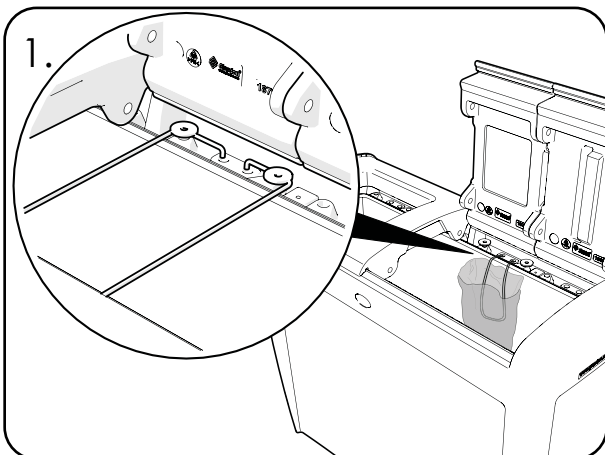

Step 1 - To insert sacks - release the bungee cord from the upstands.

Step 2 - Place the sack in position and drop the loose bungee into the sack.

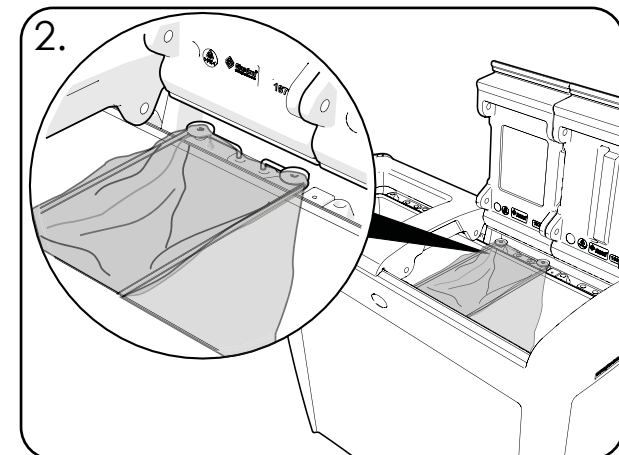

Step 3 - Stretch the sack over the rear upstands and hold in place with the bungee.

Step 4 - Stretch the bungee and sack over the front upstands to secure the sack.

Cup Stacker and Reservoir Operation

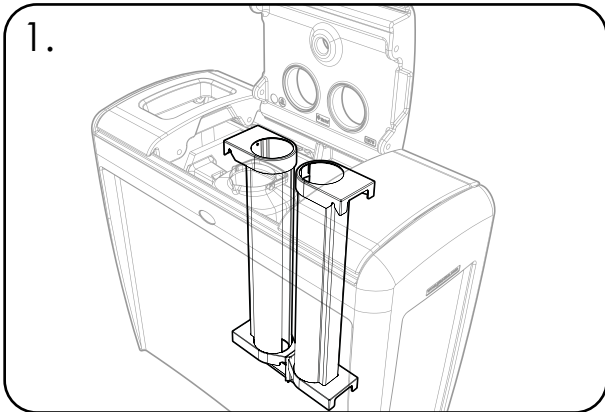

1. To Remove the cup stacker from the unit to empty the cups, open the aperture panel.

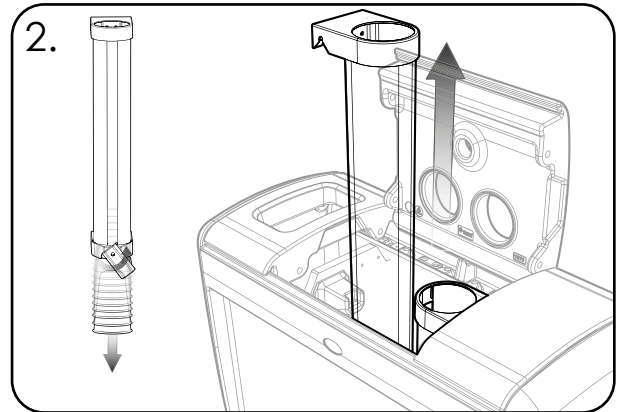

2. Lift the stacker off the support fixings. Use the quick release mechanism to release the cups. Place the stacker back onto the support fixings.

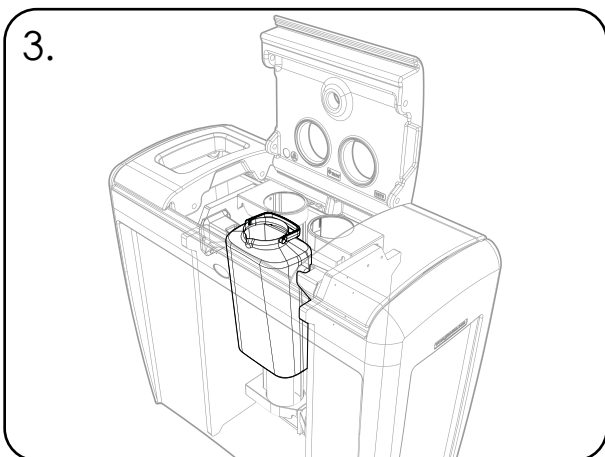

3. Empty the liquid reservoir by lifting it from the unit by the carry handle. Pour away the contents.

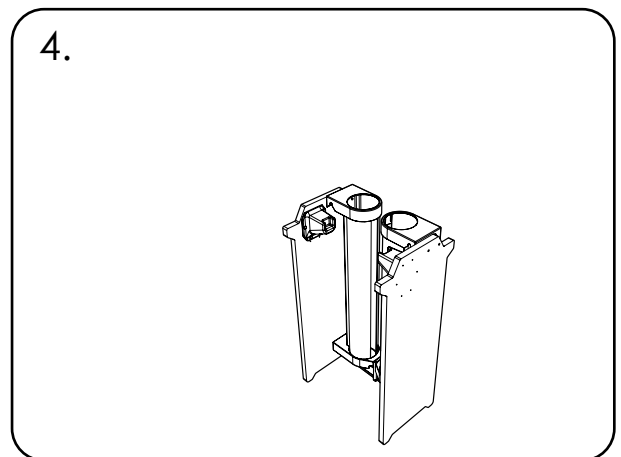

4. Replace the reservoir with the spout facing forward.

Wheel Kit Installation

Kit Contents:

ITEM 1	Wheels	x2
ITEM 2	Screw M6 x 16mm	x8
ITEM 3	4mm Allen Key	x1

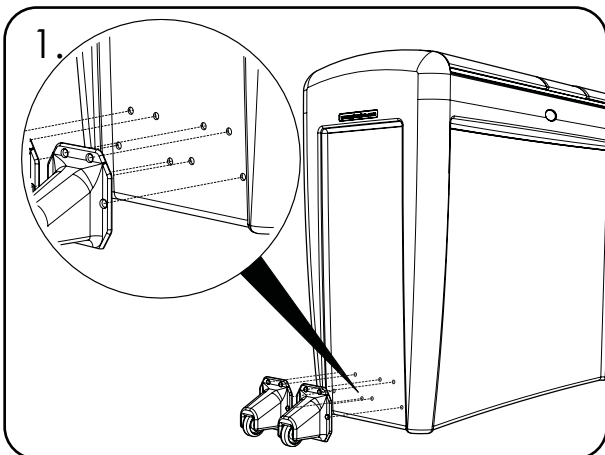
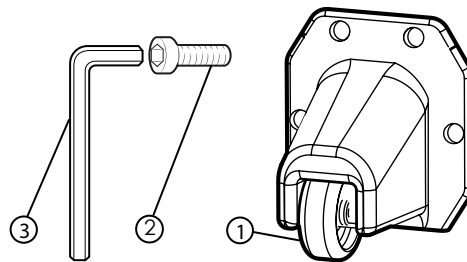

1. Line up wheels (Item 1) with fixing holes on side of the body.

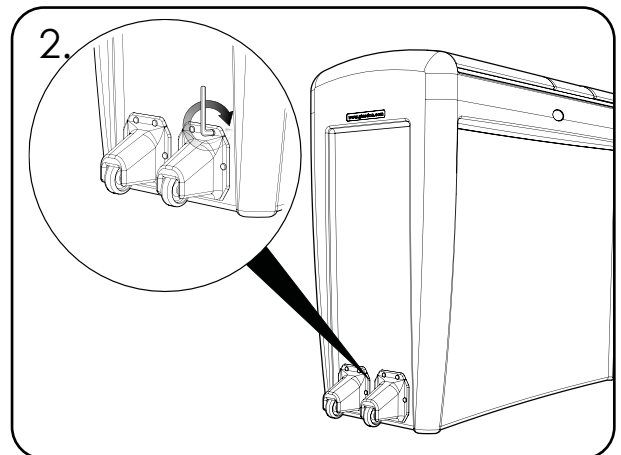

2. Insert screws (Item 2) through holes and tighten using Allen Key (Item 3).

Wheel Operations

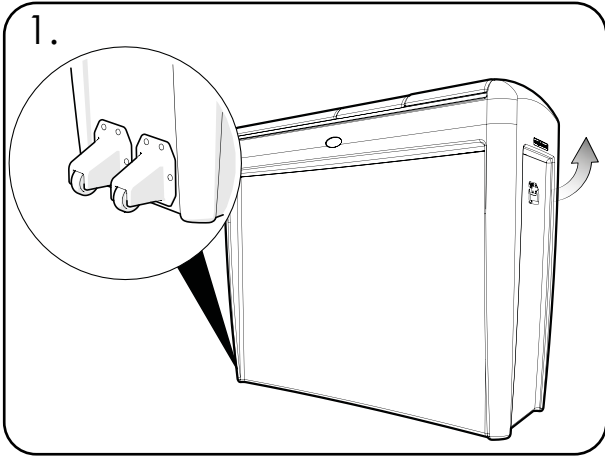

Use the handle to lift and tilt the bin until the wheels touch the ground allowing bin to be manoeuvrable.



Lock Kit Operations

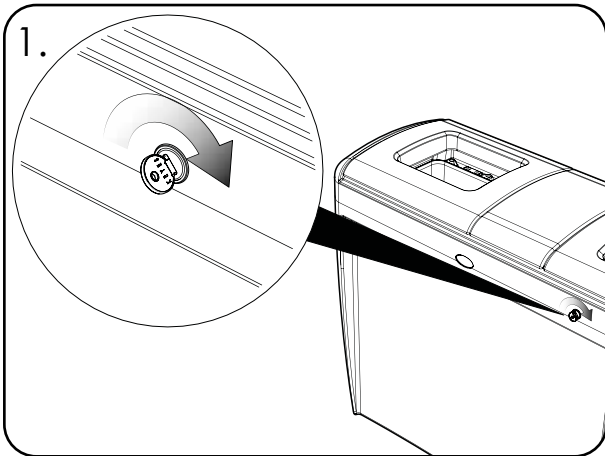

To unlock, twist key to 45 degrees clockwise until the barrel retracts.

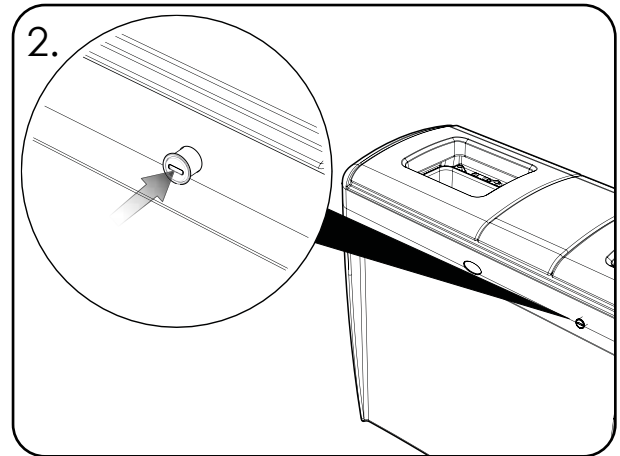

To lock, twist 45 degrees anti-clockwise and push the barrel inward.

Aperture Removal/Replacement

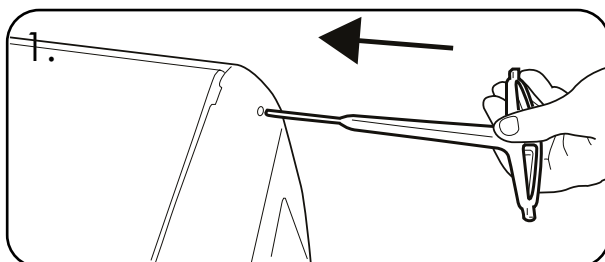

APERTURE REMOVAL

Locate the hole on the side on the product that is in line with the hinge of the lid. Insert the key into the hole to compress the 'hinge rod' and pull the apertures upwards to remove (keep your finger on the end of the hinge rod as it can spring forward and out of the metal casing). Remove the two white washers and keep safe as these will be required during the replacement of the apertures. Slide the apertures off the hinge rod.

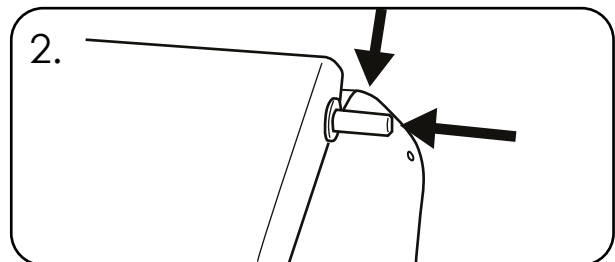

APERTURE REPLACEMENT

Place the first white washer onto the hinge rod and slide the apertures on. Next locate the left hand side of the hinge rod into the fixing hole.

Slide the second white washer onto the hinge rod and press it in whilst pushing down on the aperture to locate it back into the fixing hole.

Sign Kit Installation

Kit Contents:

Item 1	Sign Board	x1
Item 2	Washer - M6 x 18mm	x6
Item 3	Screw - M6 x 20mm	x6
Item 4	4mm Allen Key	x1

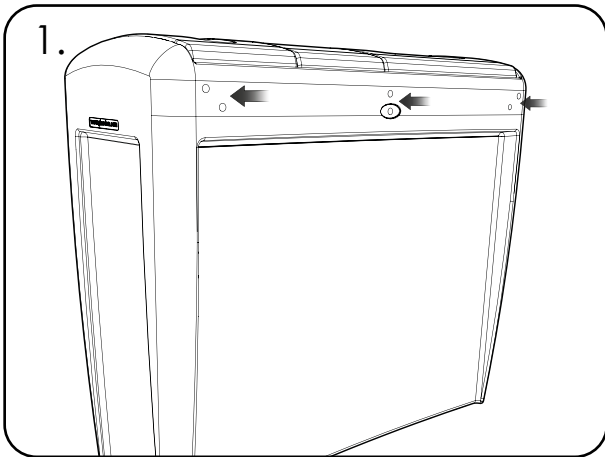

1. Locate the fixing positions on the rear of the unit.

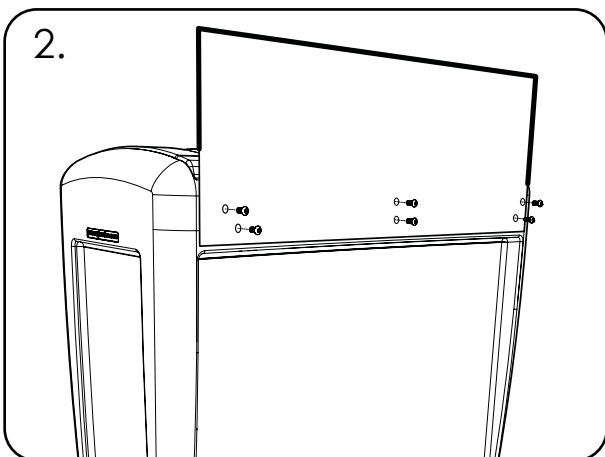

2. Position the sign carrier (item 1) and align the six fixing holes on the rear of the unit.

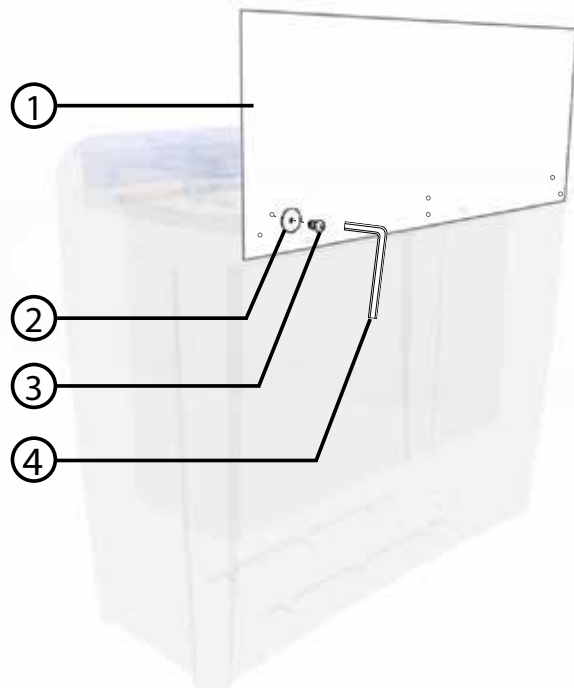

3. Fit the washers (Item 2) onto screws (Item 3) and fix through the holes in the backboard using Allen key (Item 4) to tighten.

IMPORTANT NOTE: PLEASE ENSURE THAT ALL RELEVANT PERSONNEL READ THE POINTS LISTED WITHIN THIS LEAFLET AND THAT A COPY IS GIVEN TO STAFF INVOLVED WITH THE INSTALLATION AND MAINTENANCE OF THIS PRODUCT
SAFETY NOTE: PLEASE REFER TO 'THE MANUAL HANDLING OPERATIONS REGULATIONS 1992' DURING HANDLING.

 **Glasdon** AND NEXUS ARE REGISTERED TRADEMARKS OF GLASDON GROUP OR ITS SUBSIDIARIES IN THE U.K. AND OTHER COUNTRIES

- A planned maintenance schedule or regular inspection is recommended, replacing components as necessary.
- Replacement components are available direct from GLASDON.
- GLASDON cannot be held responsible for claims arising from incorrect installation, unauthorised modifications or misuse of the product.

Stock No. C000/0524 - DWG No. 07B-372-44 Issue 2 - September 2021

© Copyright September 2021

Glasdon UK Ltd reserve the right to alter specifications without prior notice.

 **Glasdon**[®]

Glasdon U.K. Limited
Preston New Road
BLACKPOOL
Lancashire
FY4 4UL
Tel: (01253) 600410
Fax: (01253) 792558
e-mail: sales@glasdon-uk.co.uk
web: www.glasdon.com