

# Glasdon HAZARDMASTER™

## RECOMMENDED INSTALLATION INSTRUCTIONS

### WARNING: Check for buried services.

During the installation please be safe. Where necessary sign and guard your works safely with reference to New Road & Streetworks Act 1991 Chapter 8 T.S.R. & G.D.



### METHOD

Read carefully before installation. Important: Ensure all relevant personnel read the points listed below and that a copy is passed onto the end user.

- 1) After first checking the intended site for buried underground services, mark up and dig hole approximately 400mm x 400mm x 400mm deep minimum.
- 2) Place gravel to a depth of 100mm into the hole. Bed the post down onto the gravel until the ground level indicator is aligned with the top surface (as shown in Diagram B). Check that the orientation is correct, see overleaf for model specification.
- 3) Mix up enough cement and aggregate mix to fill up to the final wearing course and distribute into the hole over the post base. If the installation time must be reduced you may use a fast setting concrete e.g. **ULTRA CRETE QC10 RAPID STRENGTH 10MM CONCRETE.**

Finish off the top surface level with the final wearing course after first checking the vertical position with a spirit level and adjusting accordingly.

NOTE: See diag's C-D overleaf for alternative finishing suggestions.

**ENSURE THAT THE VERTICAL POSITION CAN BE MAINTAINED OVER THE SETTING PERIOD.**

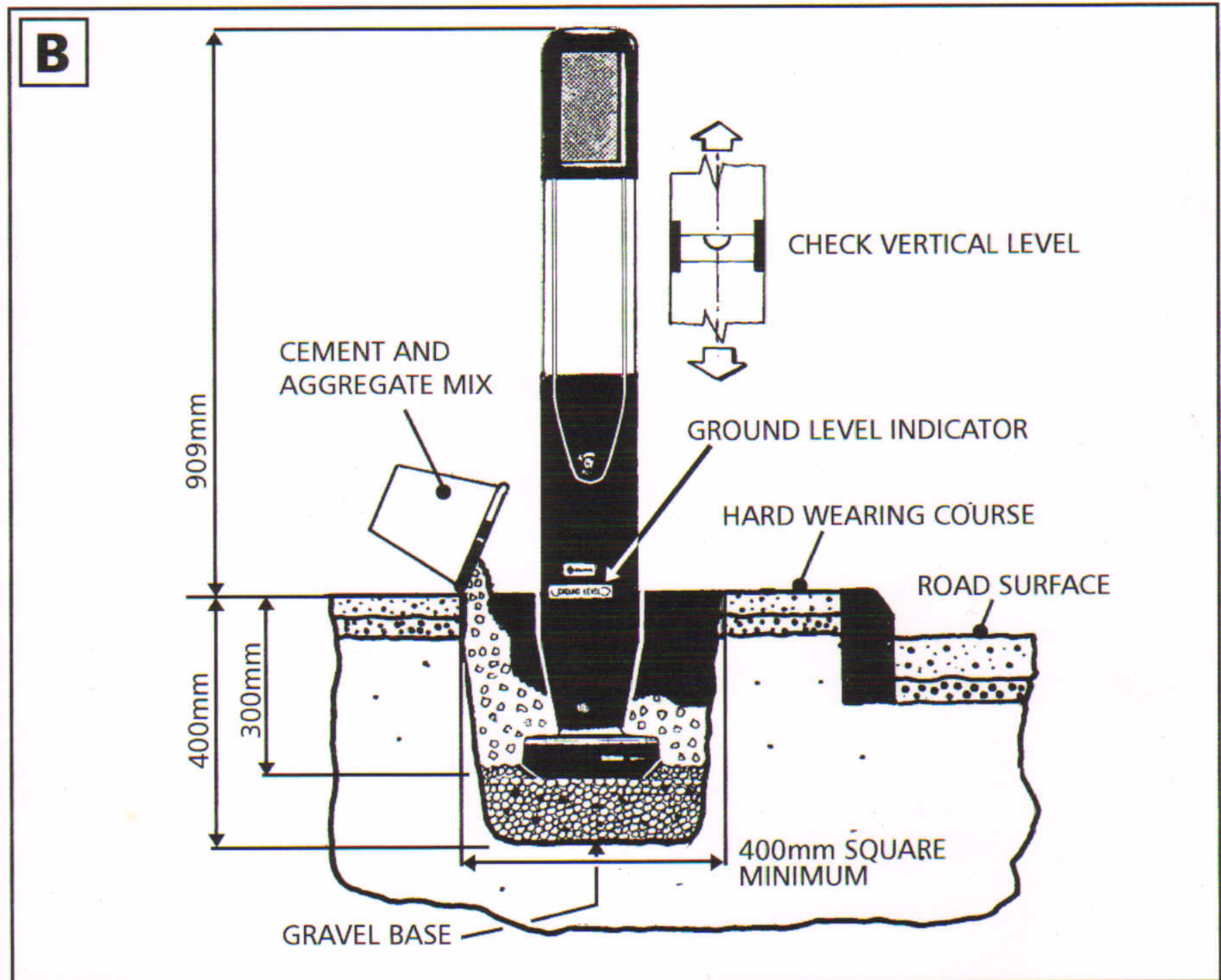



# MODEL SPECIFICATION FOR THE INSTALLATION OF GLASDON HAZARDMASTER™

INSTALLATION OF THE GLASDON HAZARDMASTER™ SHOULD INCLUDE THE FOLLOWING

- 1) Correct orientation of Red/White retroreflective band.  
NOTE: When viewed in the direction of traffic flow the colour Red should be showing on the left hand side of the carriageway and the colour White on the right.
- 2) The post should be bedded onto sufficient gravel to allow adjustment to its correct height according to the wearing surface. This is indicated on the exterior face of the post near to the ground level location point.
- 3) The vertical position of the post to be maintained during concrete setting period.
- 4) The recommended ground conditions essential to its correct performance during vehicle impact are as shown in installation instructions.

**C**

## TARMAC FINISH

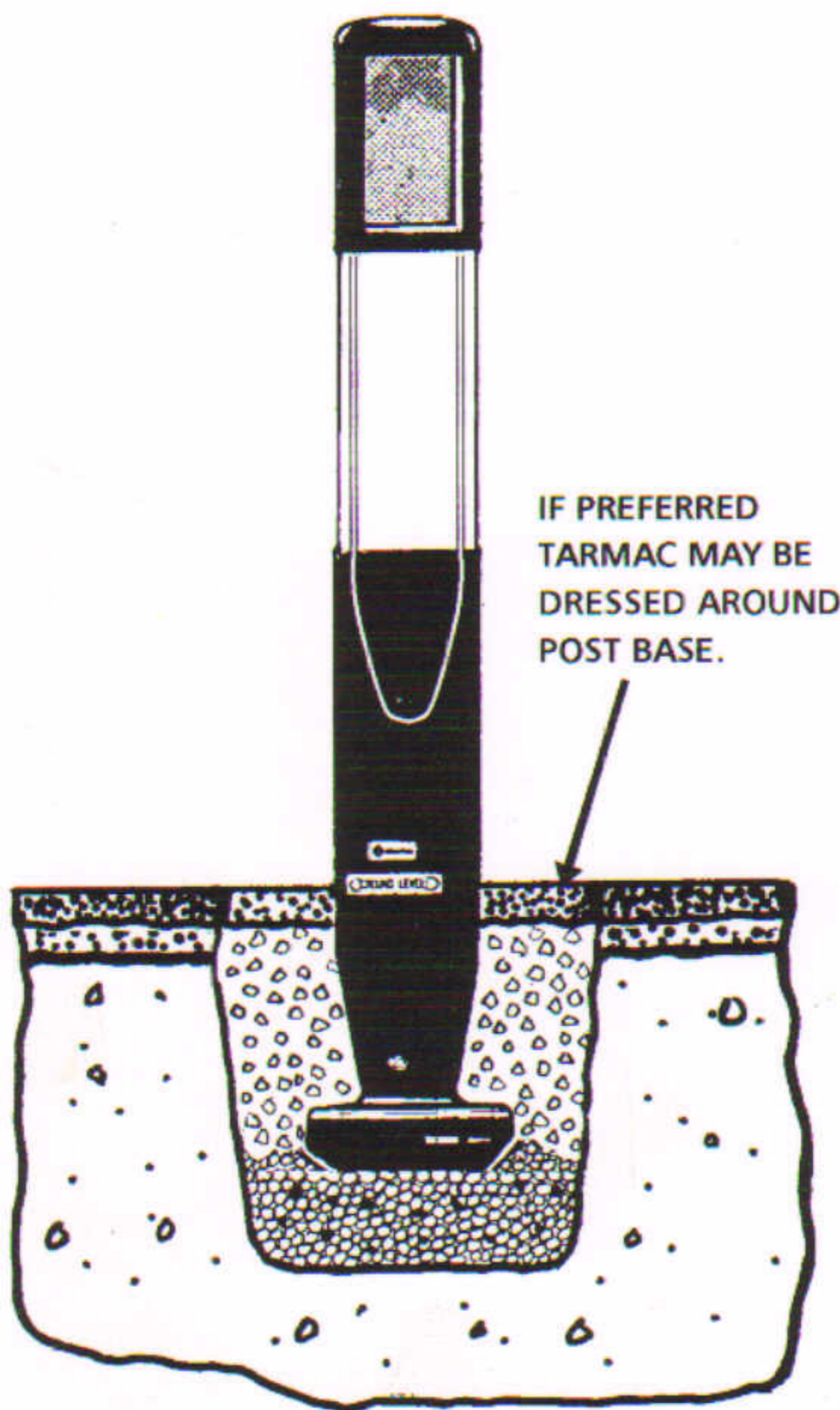

**D**

## BRICK SET FINISH

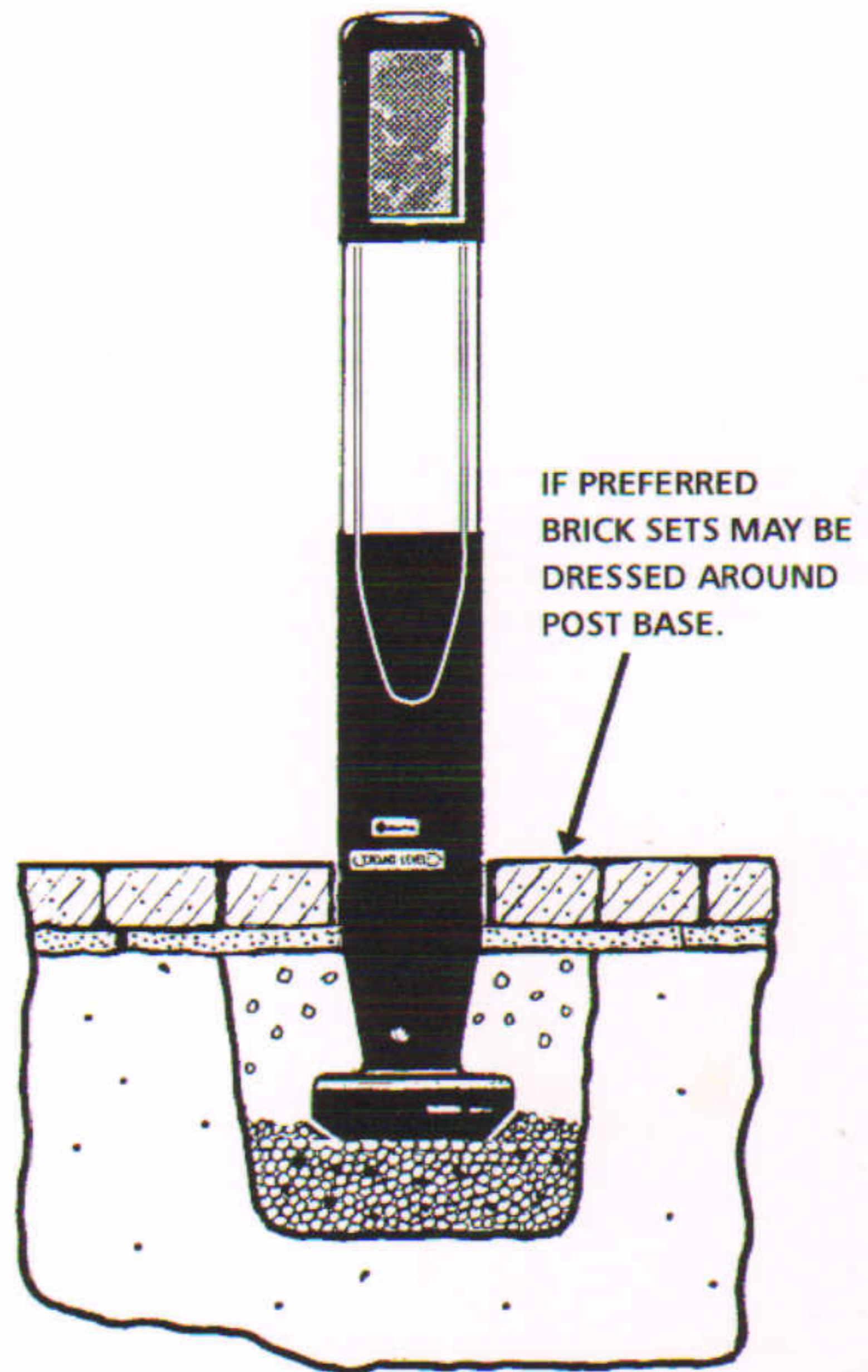

**Glasdon** AND HAZARDMASTER ARE TRADEMARKS OR REGISTERED TRADEMARKS OF GLASDON GROUP OR ITS SUBSIDIARIES IN THE U.K. AND OTHER COUNTRIES.

- A planned maintenance schedule of regular inspection is recommended, replacing components as necessary.
- Replacement components are available direct from GLASDON UK LTD.
- GLASDON UK LTD cannot be held responsible for claims arising from incorrect installation, unauthorised modifications or misuse of the product.

Issue 2 JULY 2004 Stock no. C000/0185

© Copyright July 2004

Glasdon UK Ltd. reserve the right to alter specification without prior notice. LR/7.04



**Glasdon**

**Glasdon U.K. Limited**

Preston New Road  
BLACKPOOL  
Lancashire FY4 4UL

Tel: 01253 600410

Fax: 01253 792558

e-mail: sales@glasdon-uk.co.uk

web: www.glasdon.com