



TURBOCAST 800™

Towable Grit/Salt Spreader

Spares Manual



Glasdon U.K. Limited
Preston New Road
BLACKPOOL
Lancashire
FY4 4UL

Tel: (01253) 600410

Fax: (01253) 792558

e-mail: sales@glasdon-uk.co.uk



www.glasdon.com

Spares Manual





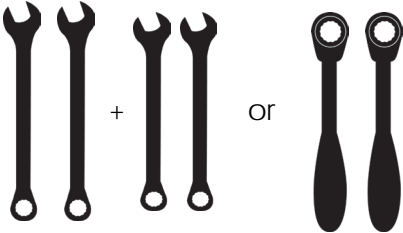
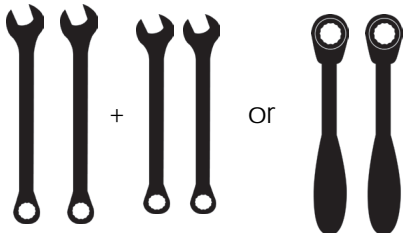

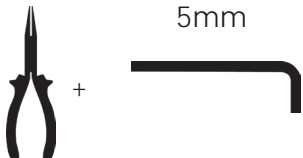
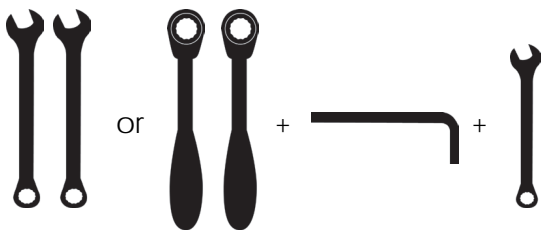
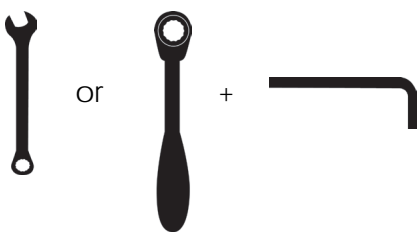







Thank you for purchasing a Glasdon Turbocast 800 Towable Grit/Salt Spreader. This manual contains important information for how your product is put together and how to maintain or replace parts during its lifetime. Your product has been designed to last for many years, however regular inspection and replacement of wearing parts may be required from time to time to keep your machine in prime working order. It is recommended that the machine is thoroughly inspected and serviced prior to storing the machine away for extended periods e.g. at the end of the Winter season - so that your machine is ready to be used as soon as conditions demand.

CONTENTS	PAGE
SECTION 1 SPARES KITS - TOOLS & CONTENTS	2
SECTION 2 PARTS LIST	7
SECTION 3 EXPLODED VIEWS	10
FIG 1. Ball Hitch Assembly	10
FIG 2. Pin Hitch Assembly	10
FIG 3. Mudguard / Cover Flap Assembly	11
FIG 4. Drive Cover and Chain Tensioner Assembly	12
FIG 5. Chains Assembly	13
FIG 6. Spinner Shaft Sprocket Assembly	14
FIG 7. Agitator Shaft Assembly - Sprockets and Clutch	14
FIG 8. Agitator Shaft Assembly - Cams and Bearings	15
FIG 9. Clutch and Cam Handle Assembly	15
FIG. 10 Spinner Plate / Spread Limiter Assembly	16
FIG. 11 Wheel and Free Hub Assembly	16
FIG. 12 Drive Shaft Hub Sprocket Assembly	17
FIG. 13 Agitator Mat and Fingers Assembly	17
FIG. 14 Lighting Assembly	18
FIG. 15 Flow Control Assembly	18
FIG. 16 Drive Wheel Assembly	19
SECTION 4 MECHANICS	20
FIG 17. Drive System	20
FIG 18. Agitation System	21
FIG 19. Flow Control Mechanism	22

















1 Spares Kits - Tools & Contents

KITS:	TOOLS REQUIRED:	KIT CONTENTS:	FIGURE:
KIT 1. Spare Pin Hitch Kit.	19mm 17mm 2 x 17mm & 2 x 19mm Socket Set 	163 164 (x2) 169 210 211 212 213 214 (x2) 215 (x4)	2
KIT 2. Spare Ball Hitch Kit.	19mm 17mm 2 x 17mm & 2 x 19mm Socket Set 	155 156 157 162 (x2) 163 (x3) 164 (x6) 169	1
KIT 3. Chain for Agitation to Spinner Plate.		103	5
KIT 4. Chain for Main Shaft to Agitation System.		104	5
KIT 5. Spare Chain Tensioning Kit (Pair).		100 (x2) 101 (x4) 111 (x2) 113 (x4) 116 (x4)	4
KIT 6. Spare Agitator Shaft Assembly Kit.	17mm 2 x 17mm & 2 x 13mm 6mm 13mm Socket Set 	67 68 (x10) 69 (x2) 70 (x2) 83 (x20) 84 (x20) 85 (x20) 86 (x4) 87 (x4) 88 (x4)	7
KIT 7. Spare Agitator Cam Kit.	13mm 13mm Socket 6mm 	68 (x2) 83 (x4) 84 (x4) 85 (x4)	7















1 Spares Kits - Tools & Contents

KITS:	TOOLS REQUIRED:			KIT CONTENTS:	FIGURE:
KIT 8. Spare Agitator Finger & Roller Kit.	10mm 	or 10mm Socket 	+ 5mm 	118 122 123 124 125	12
KIT 9. Spare Agitator Mat Kit.	10mm 	or 10mm Socket 	+ 5mm 	117 122 (x5) 123 (x5) 124 (x5) 125 (x5) 128 (x2) 129 (x2)	12
KIT 10. Spare 45 Tooth Sprocket Kit.	10mm 	or 10mm Socket 	+ 5mm 	71 89 90	6
KIT 11. Spare 15 Tooth Sprocket Kit (25 Bore).	5mm 			72 73 74 91	6
KIT 12. Spare 38 Tooth Sprocket Kit.	10mm 	or 10mm Socket 			
KIT 13. Spare 15 Tooth Sprocket Kit (26 Bore).	10mm 	or 10mm Socket 			

1 Spares Kits - Tools & Contents

KITS:	TOOLS REQUIRED:			KIT CONTENTS:	FIGURE:
KIT 14. Spare Drive Engagement Clutches Kit.	5.5mm 	5.5mm Socket or 	2.5 & 4mm 	118 (x2) 122 (x3) 123 (x3) 124 (x3) 125 (x3)	6, 8
KIT 15. Spare Drive Engagement Handle Kit.	10mm 	10mm Socket or 	5mm 	78 79 90 96 97 (x2)	8
KIT 16. Spare Spinner Plate Assembly Kit.	5mm 			38 39 (x2) 40 (x2)	9
KIT 17. Spare Spinner Plate Shaft Kit.	13mm 	13mm Socket or 	6mm 	37 41 (x4) 42 (x4) 43 (x4)	9
KIT 18. Spare Wheel Nuts Kit.	17mm 	17mm Socket or 	or 	154 (x4)	10
KIT 19. Spare Wheel Kit.	17mm 	17mm Socket or 	or 	145	10

1 Spares Kits - Tools & Contents

KITS:	TOOLS REQUIRED:				KIT CONTENTS:	FIGURE:
KIT 20. Spare Electrical Extension Kit.	-				118 122 123 124 125	-
KIT 21. Spare Light Cluster Set Kit.	10mm 	or 10mm Socket 	+ 5mm 	+ Phillips 	179 180 188 (x4) 189 (x4)	13
KIT 22. Spare Left Hand Light Cluster Kit.	10mm 	or 10mm Socket 	+ Phillips 		180 188 (x2) 189 (x2)	13
KIT 23. Spare Right Hand Light Cluster Kit.	10mm 	or 10mm Socket 	+ Phillips 		179 188 (x2) 189 (x2)	13
KIT 24. Spare Fog Light Kit.	10mm 	or 10mm Socket 	+ Phillips 		181 188 (x2) 189 (x2)	13
KIT 25. Spare Spread Limiter Kit.	17mm 		or 17mm Socket 		170 172 173 (x4) 175 176 177 (x2)	9

1 Spares Kits - Tools & Contents

KITS:	TOOLS REQUIRED:	KIT CONTENTS:	FIGURE:
<p>KIT 26. Spare Drive Wheel Assembly Kit.</p>	<p>17mm 2 x 17mm & 2 x 10mm 10mm Socket Set</p>  <p>The illustration shows two 17mm open-end wrenches on the left. In the center, there are two 17mm sockets and two 10mm sockets, with the text '2 x 17mm & 2 x 10mm Socket Set' above them. On the right, there is one 10mm open-end wrench. The word 'or' is placed between the wrenches and sockets, and a '+' sign is placed between the sockets and the 10mm wrench.</p>	<p>20 21 22 24 28 (x2) 29 (x4) 30</p>	<p>16</p>
<p>KIT 27. Spare PVC Hopper Cover Kit.</p>	<p>-</p>	<p>207</p>	<p>-</p>

Prior to attempting replacement of any parts please ensure you have a good understanding of how the kit you wish to fit should be fitted to the machine. Check that you have the correct tools and expertise to carry out the replacement.

The **Exploded views** in **Section 3** give a complete overview of all the assemblies which make up your gritting machine. Below each drawing description there is listed the kit numbers relevant to that particular figure.

In addition to an exploded view showing how the parts of the machine are put together - each illustration also includes (where applicable) recommended maintenance that should be carried out whilst the machine is part disassembled and so parts are fully accessible. Please carry out these maintenance procedures as these will help ensure the long lifespan of the machine.

2

Parts List

PART NO.	PART DESCRIPTION	PART NO.	PART DESCRIPTION
1	Main Chassis Assembly	41	M8 x 20mm Hex Head Screw S/S
2	Axle Bearing	42	Nyloc Nut M8 S/S
3	38 Tooth Sprocket (Main Shaft)	43	Washer Plain M8 S/S
4	Main Shaft	44	Lead Screw Nut
5	Hub – Drive Side	45	Flow Mechanism Bush
6	Hub – Free Wheel Side	46	Flow Mechansim Tube Assembly
7	Hub Bearing 25	47	Lead Screw
8	Hub Bearing 30	48	Handwheel
9	Hub Cap	49	M6 x 25mm Socket Cap Screw S/S
10	M12 x 50mm Skt Bt Head S/S	50	S/S Washer M6 x 14mm O.D
11	N12 Nylock Nut S/S	51	M6 Nyloc Nut Stainless Steel
12	M12 Form B Flat Washer	52	M3 x 20mm SKT Cap Head Screw S/S
13	M6 x 100mm Hex Head Screw S/S	53	M3 Washer S/S
14	M6 Nylock Nut S/S	54	M3 Nyloc Nut S/S
15	Hex Head Screw M8 x 65mm Bolt BZP	55	M4 x 16mm SKT Cap Head Screw S/S
16	M8 Nylock Nut Hex Head BZP	56	M4 x 40mm SKT Cap Head Screw S/S
17	M20 Castle Nut	57	M4 Washer 9mm O.D. S/S
18	Plain Washer M20	58	Nut - M4 - Nyloc S/S
19	Split Pin Ø3mm x 30mm	59	Hopper - Yellow
20	Drive Wheel	60	Nylon Spacer - ID 10.2mm
21	Drive Wheel Bearing	61	Hopper Funnel Shelf
22	Drive Wheel Adaptor	62	M6 x 13mm Post Mould Insert
23	Drive Shaft	63	M10 Nyloc Nut M10 S/S
24	M6 Three Point Handwheel Orange	64	Washer Plain M10 S/S
25	Adjuster Bearing diam. 25mm	65	M10 x 60 SKT BT Screw S/S
26	See Part 25.	66	M6 x 20mm Hex Head Screw S/S
27	15 Tooth Sprocket (Spinner Shaft)	67	Agitator Shaft Assembly
28	M6 x 20mm Hex Head Screw S/S	68	Agitator Cam
29	M6 Spring Washer S/S	69	Adjuster Bearing diam. 25mm
30	Screw - M6 x 16mm Hex Head S/S	70	I/Zinc & P/Coat of Adjuster Bearing
31	M10 Nyloc Nut M10 S/S	71	45 Tooth Sprocket (Agitation Shaft)
32	Washer Plain M10 S/S	72	15 Tooth Sprocket (Agitation Shaft)
33	10.3 x 20.6 x 3.2mm Nylon Washer	73	Sprocket Bearing
34	M6 x 18 x 1.5mm Washer S/S	74	Clutch Collet
35	M6 X 60mm Hex Head Screw S/S	75	Castle Dog Clutch
36	M6 Nyloc Nut Stainless Steel	76	Clutch Spacer
37	Spinner Shaft	77	Dog Clutch Sleeve
38	Turbocast 800 Spinner Plate	78	Cam Handle
39	Turbocast 800 Spinner Bearing	79	Eye Stud (Cam Handle)
40	Two Piece Collar	80	S/S Compression Spring - 9.5mm

2

Parts List

PART NO.	PART DESCRIPTION	PART NO.	PART DESCRIPTION
81	Agitator Bearing Cover R/H	121	Mat Clamp
82	Agitator Bearing Cover L/H	122	M6x16mm Socket Button Screw S/S
83	M8 x 40mm Hex Head Bolt S/S	123	S/S Washer M6 x 14mm O.D
84	Washer Plain M8 S/S	124	M6 Nyloc Nut S/S
85	Nyloc Nut M8 S/S	125	Black Nylon Spacer
86	Screw Set Hex Head M10 x 25mm S/S	126	M8 x 20mm Hex Head Screw S/S
87	M10 Nyloc Nut M10 S/S	127	Washer Plain M8 S/S
88	Washer Plain M10 S/S	128	M6 Penny Washer S/S
89	M6 x 100mm Hex Head Screw BZP	129	M6 x 20mm Hex Head Screw S/S
90	M6 Nyloc Nut S/S	130	Mudguard R/H
91	M5 x 10mm Grub Screw	131	Mudguard L/H
92	M4 x 10mm CSK Screw S/S	132	Clutch Access Flap L/H
93	M3 x 40mm SKT BT Screw BZP	133	Clutch Access Flap R/H
94	M3 Nyloc Nut S/S	134	Single Point Cam38 Steel
95	M3 Washer S/S	135	Toothed Lock Washer
96	M6 x 20mm Socket Button Screw S/S	136	Wing Knob Polymide Housing
97	S/S Washer M6 x 14mm O.D	137	Wing Knob - Lock Insert
98	M6 x 16mm Socket Head Screw S/S	138	Flat External Seal
99	M6 x 13mm Post Mould Insert	139	O-Ring for Wing Lock Assembly
100	Chain Tensioner	140	S/S Washer M6 x 14mm O.D
101	10.2 x 20 x 12mm Nylon 66	141	M6 x 12mm S/S Button Head
102	Tensioner Bracket	142	75mm Hinge S/S Clutch Access Flap
103	S/S Chain Pitch 110 c/w Connectors	143	Ashtray Retaining Bracket
104	S/S Chain Pitch 83 c/w Connectors	144	Spray Suppression Mud Flap
105	Hopper Underside Plate R/H	145	Wheel Assembly
106	Hopper Underside Plate L/H	146	Rivet 4.8x18x10mm Black Alu
107	Right Hand Chassis Cover	147	M5 x 16 SKT BT Screw S/S
108	Left Hand Chassis Cover	148	M5 Nyloc Nut S/S
109	Hopper Front Side Panel	149	M5 x 12.5 x 1mm Washer S/S
110	Hopper Rear Side Panel	150	Rivet 4x11.5 S/S
111	Split Pin 2.5 x 40mm S/S	151	M6 x 20 Skt Cap Screw S/S
112	M6 x 50mm Hex Head Screw S/S	152	M6 Nyloc Nut S/S
113	S/S Washer M6 x 14mm O.D	153	S/S Washer M6 x 14mm O.D
114	M6 Nyloc Nut S/S	154	Wheel Nut Metric
115	M6 x 20mm Hex Head Screw S/S	155	Tow Bar Hitch
116	M6 x 20mm Hex Head Screw S/S	156	Coupling U/B Cast 50mm Ball H/D
117	Agitator Mat	157	ISCP200 Secondary Break Cable
118	Agitator Finger	158	Tow Bar
119	Agitator Hinge	159	Jockey Wheel Spacer
120	Agitator Hinge Rod 8mm x 400mm S/S	160	Jockey Wheel Clamp

2

Parts List

PART NO.	PART DESCRIPTION	PART NO.	PART DESCRIPTION
161	Jockey Wheel	201	Drive Instructions External Sticker
162	M12 x 120 Hex Head Bolt S/S	202	Drive Instructions Internal Sticker
163	M12 Nylock Nut S/S	203	Polycarb Plaque "Spreading"
164	M12 A2 Form B Flat Washer	204	Data Plate S/S 1.5mm
165	M10 x 35mm Hex Head S/S	205	6x25mm Torx Pan Head Screw S/S
166	M10 Nyloc Nut M10 S/S	206	Bulbex Rivet - Dyed Black Top
167	M10 Washer S/S	207	Hopper Cover - Black PVC
168	Bolt Hex Head M10 x 60mm S/S	208	Instruction Leaflet
169	M12 x 80 Hex Head Bolt S/S	209	CE Certificate
170	R/M Limiter	OPTIONAL EXTRAS	
171	Limiter Bracket	210	Unbraked Towing Eye
172	Limiter Handwheel	211	Towbar Eye Hitch Extension
173	Reflector - 70 x 25mm Yellow	212	M10 X 100 Hex Head Bolt S/S
174	6x25mm Torx Pan Head Screw S/S	213	Setscrew M10 x 50 Hex Head Bolt S/S
175	M10 X 100 Hex Head Bolt S/S	214	M10 Nyloc Nut M10 S/S
176	M10 Nyloc Nut M10 S/S	215	Washer Plain M10 S/S
177	Washer Plain M10 S/S		
178	Cable, DC Connectors & 7 Pin Socket		
179	Light Cluster LHS		
180	Light Cluster RHS (with Fog Connector)		
181	Fog Light		
182	Red Triangular Reflectors		
183	Clear 90 x 40 Rectangle Reflector		
184	Amber Round Reflector		
185	2.3m Plug to Plug Straight Cable		
186	Wiring Cover Plate		
187	5 x 50 Self Tap Cross Head Pozi S/S		
188	M5 Nyloc Nut S/S		
189	M5 x 12.5 x 1mm Washer S/S		
190	4.8 x 32 Self Tap Cross Head Pozi S/S		
191	6x25mm Torx Pan Head Screw S/S		
192	S/A Vyl Stk "20"		
193	Oval Badge Glasdon		
194	Polycrown Turbocast 800		
195	Instruction & Maintenance Plaque		
196	Hitch Instructions Plaque		
197	Aperture Adjustment Wheel Plaque		
198	Handle Tree Clip		
199	Speed Adjustment Instructions Plaque		
200	Spread Limiter Instructions Plaque		

3 Exploded Views

FIG. 1 Ball Hitch Assembly
(Kit 2)

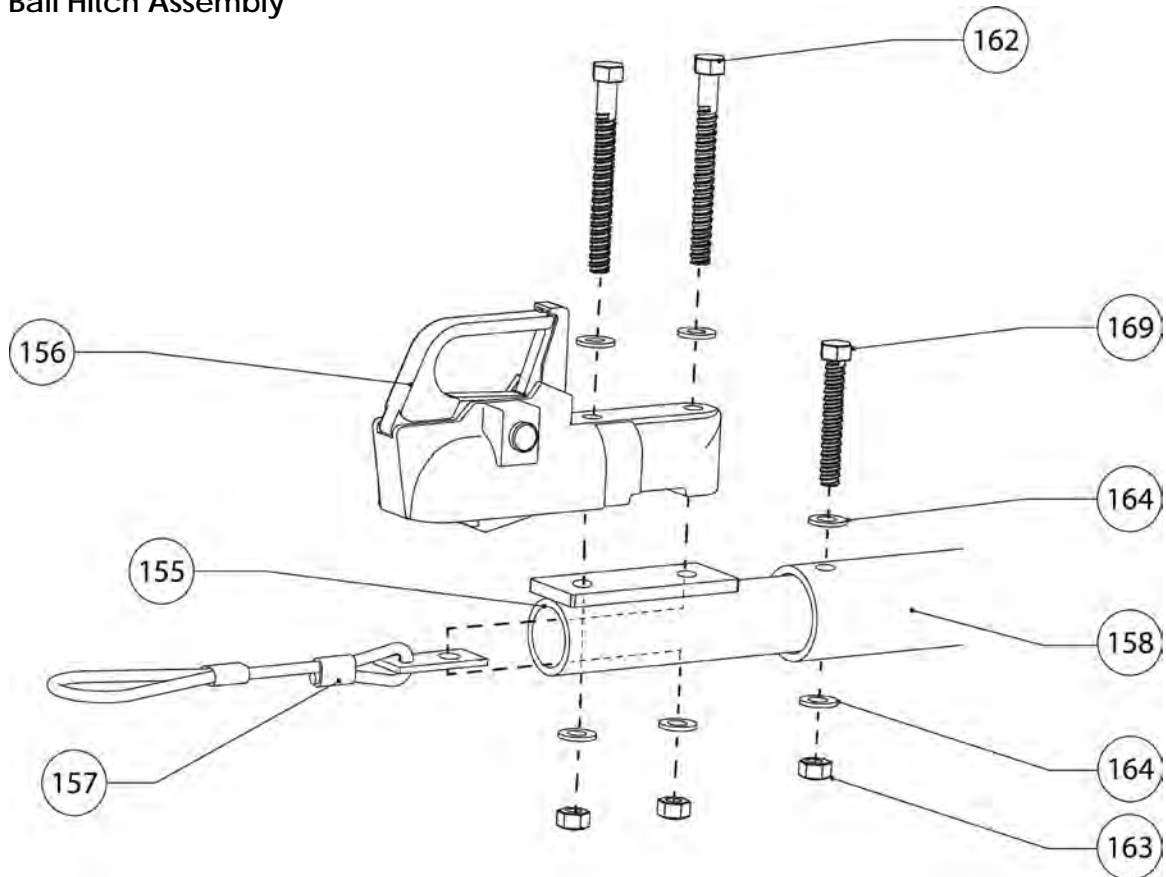
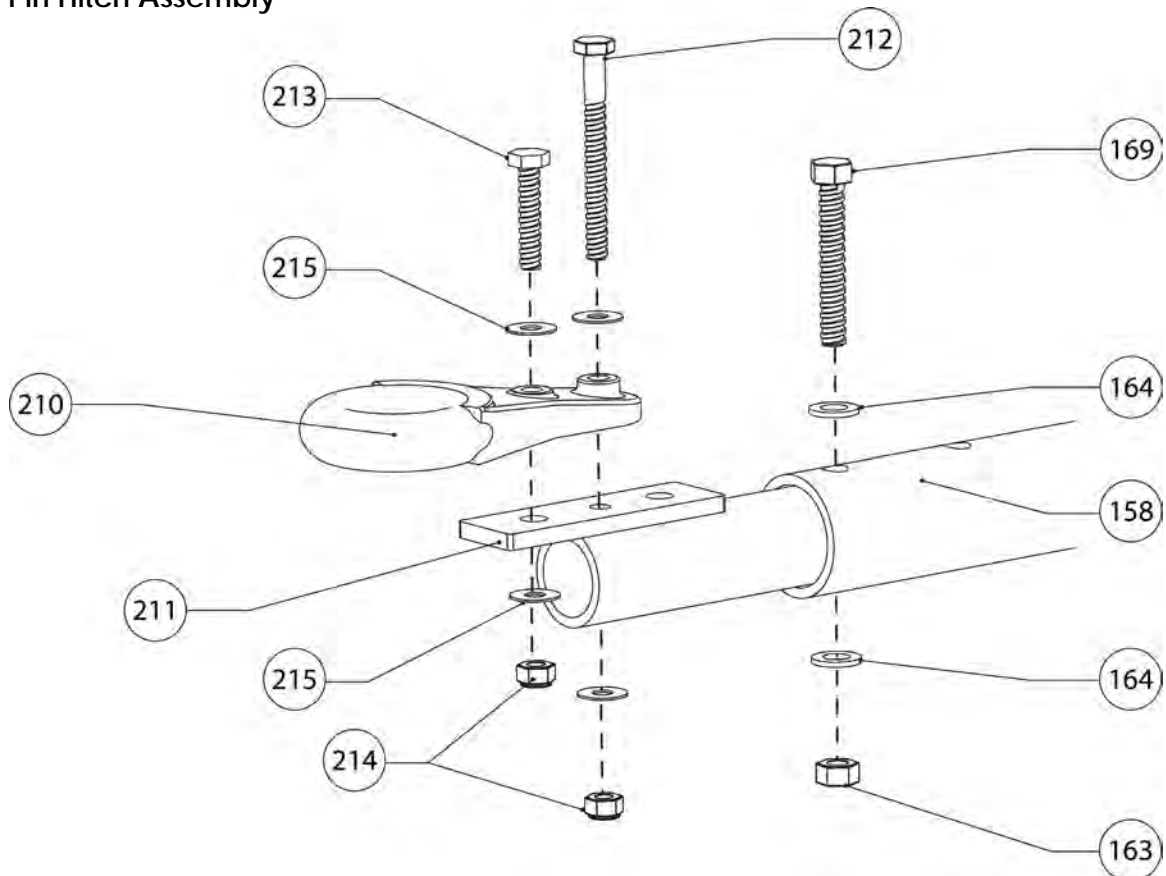
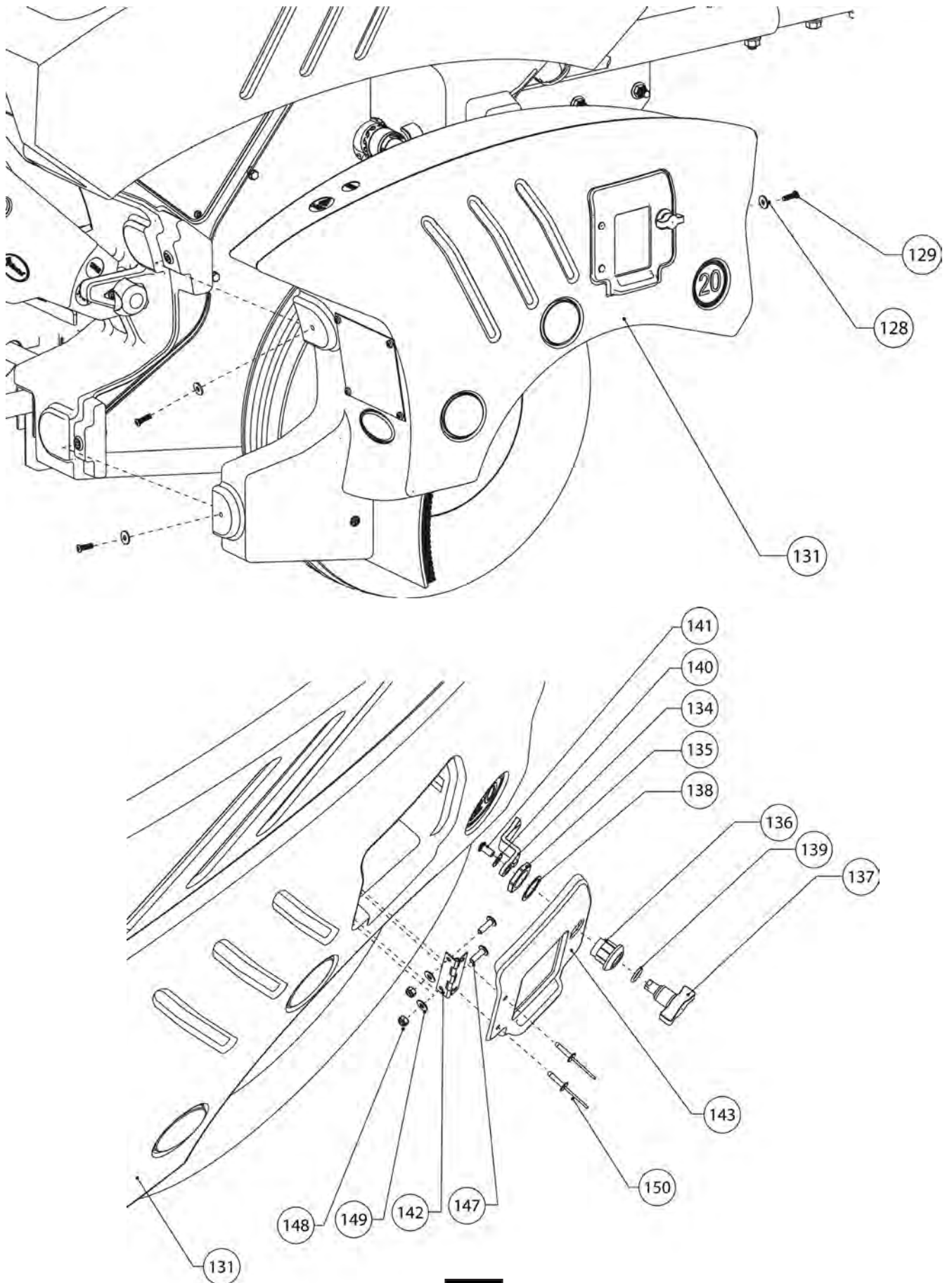

FIG. 2 Pin Hitch Assembly
(Kit 1)



3 Exploded Views

FIG. 3 Mudguard / Cover Flap Assembly



3 Exploded Views

FIG. 4 Drive Cover and Chain Tensioner Assembly
(Kit 3, 4, 5)

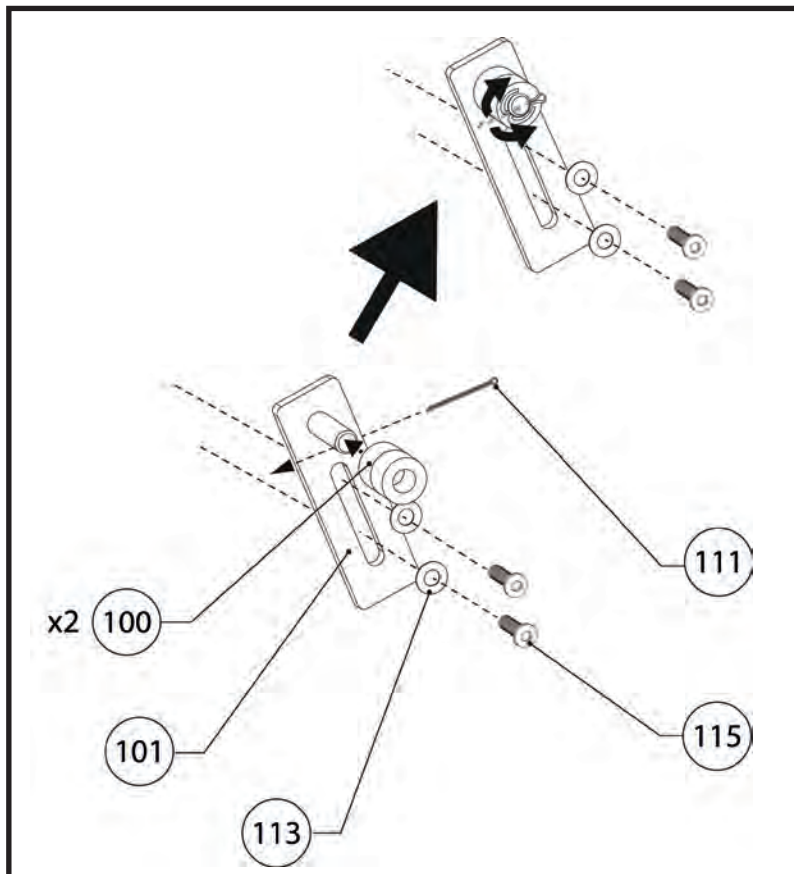
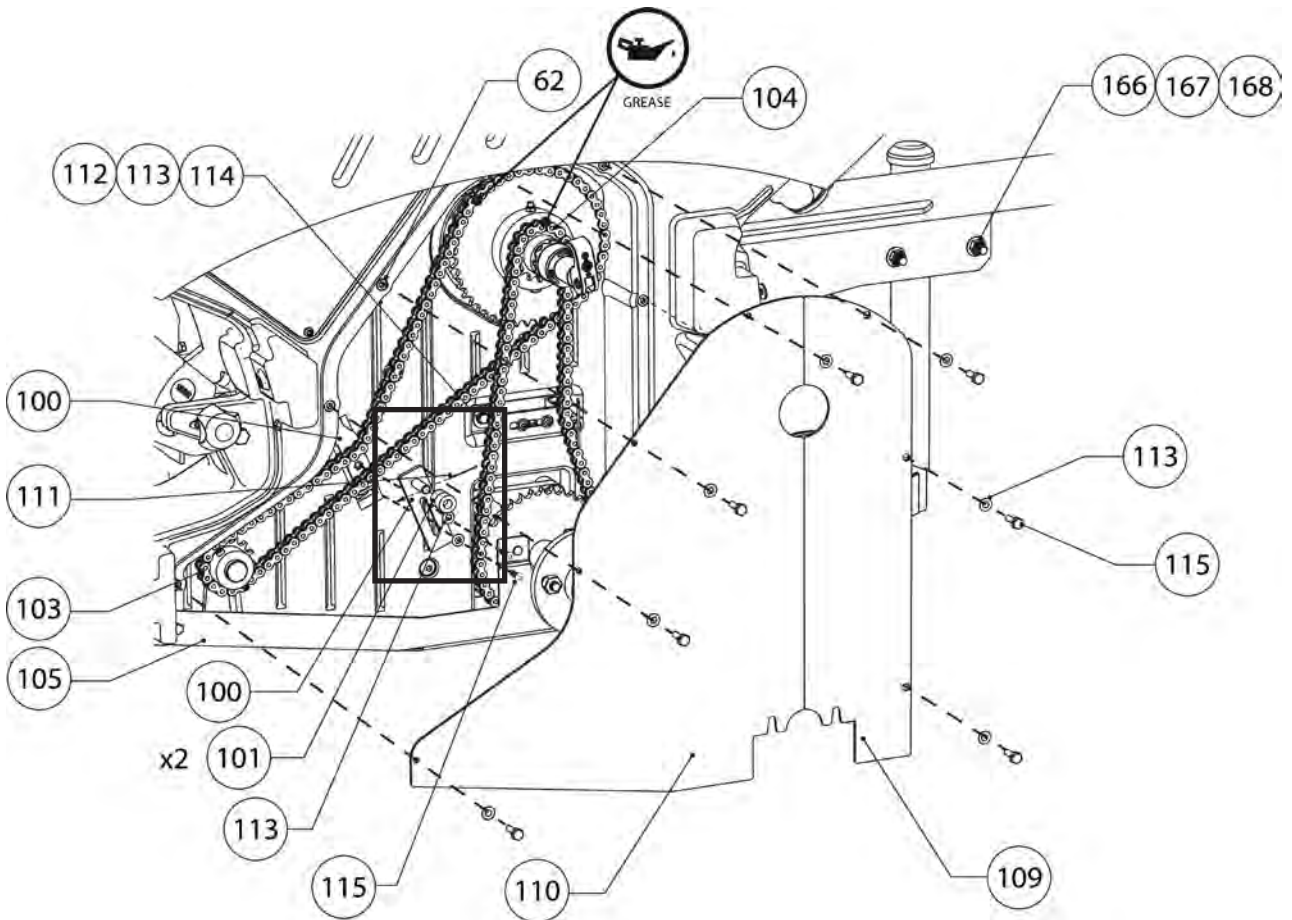

3

Exploded Views

FIG. 5 Chains Assembly
(Kit 3, 4)

Chain for Agitation to
Spinner Plate.

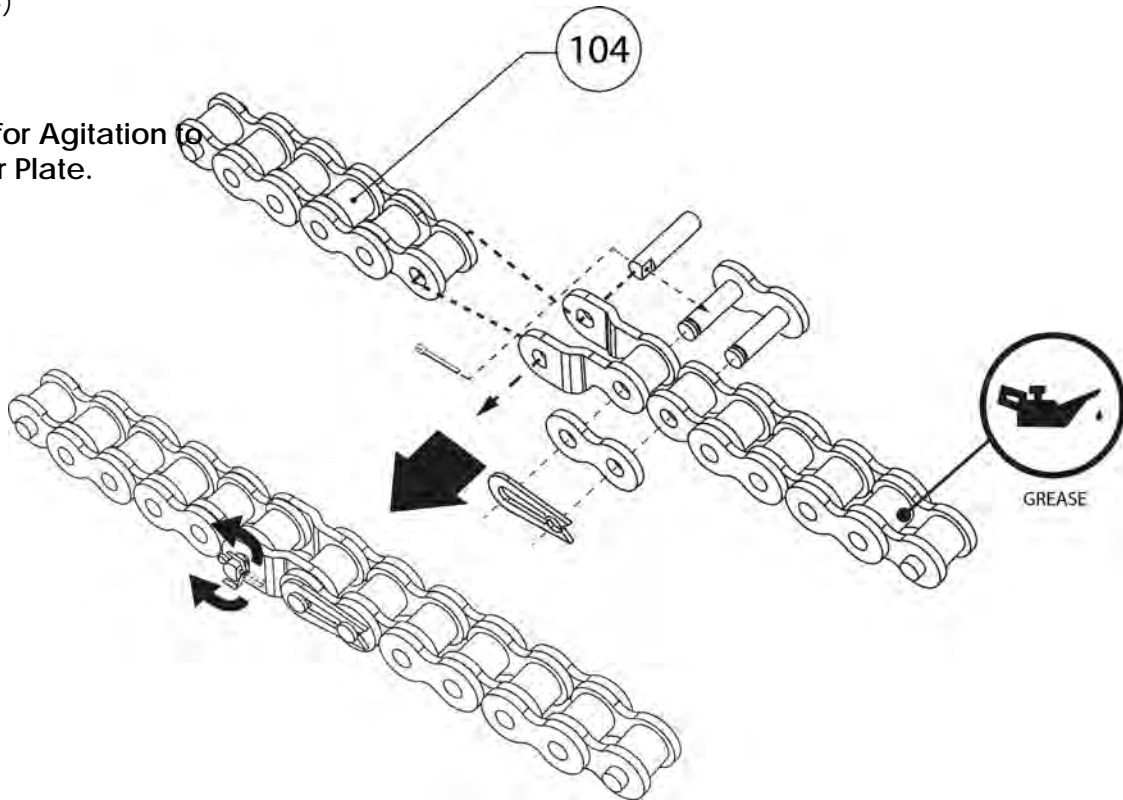

Chain for Main Shaft to
Agitation System.

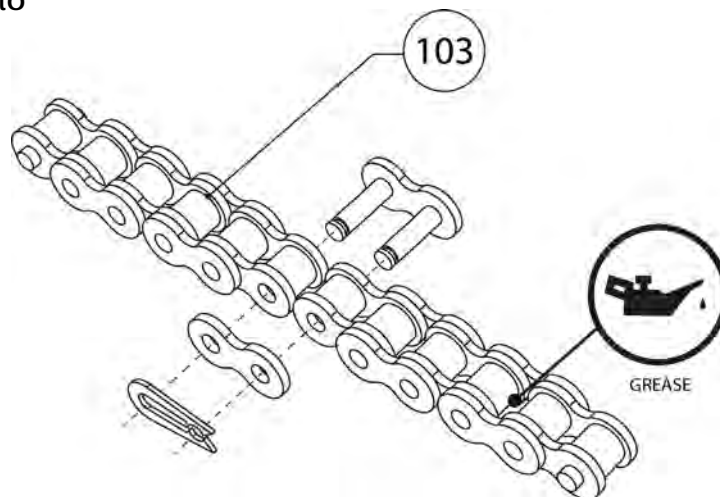

3 Exploded Views

FIG. 6 Spinner Shaft Sprocket Assembly
(Kit 13)

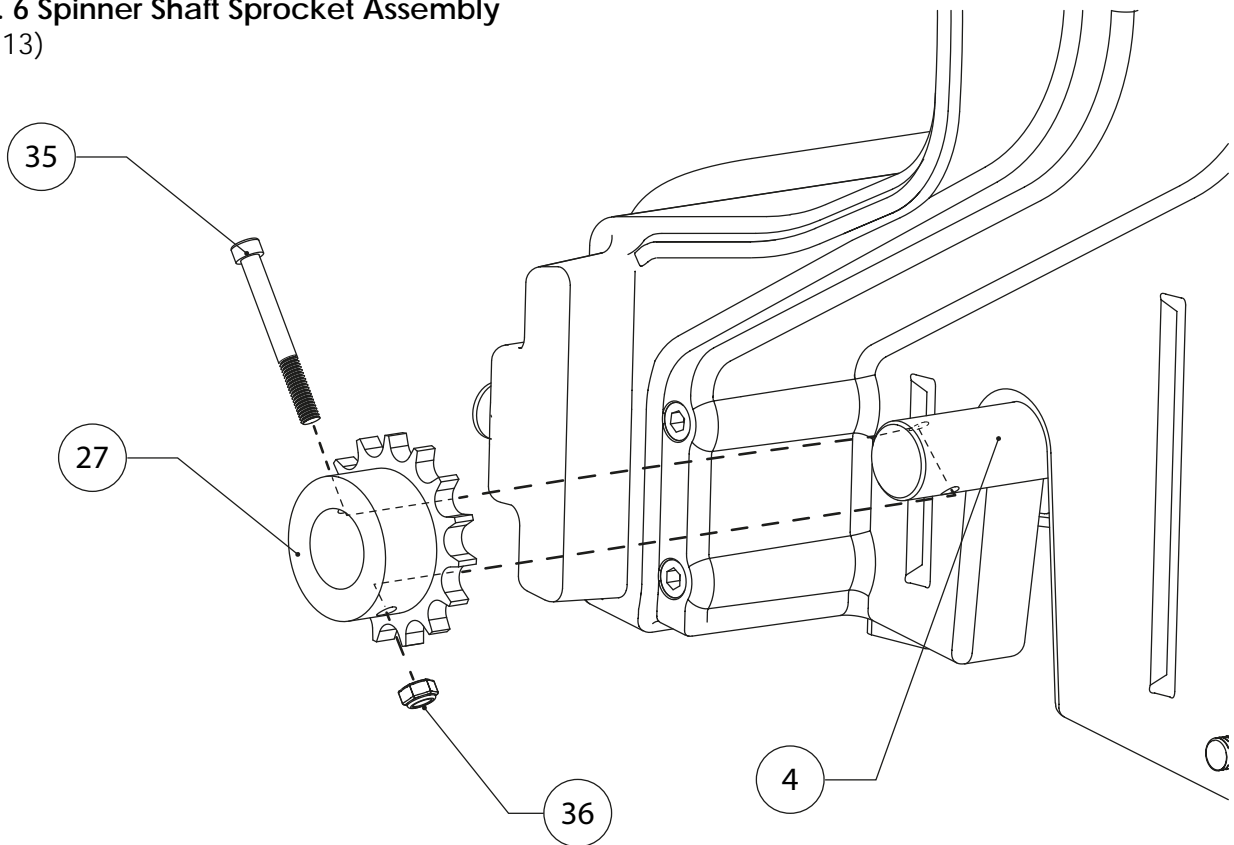
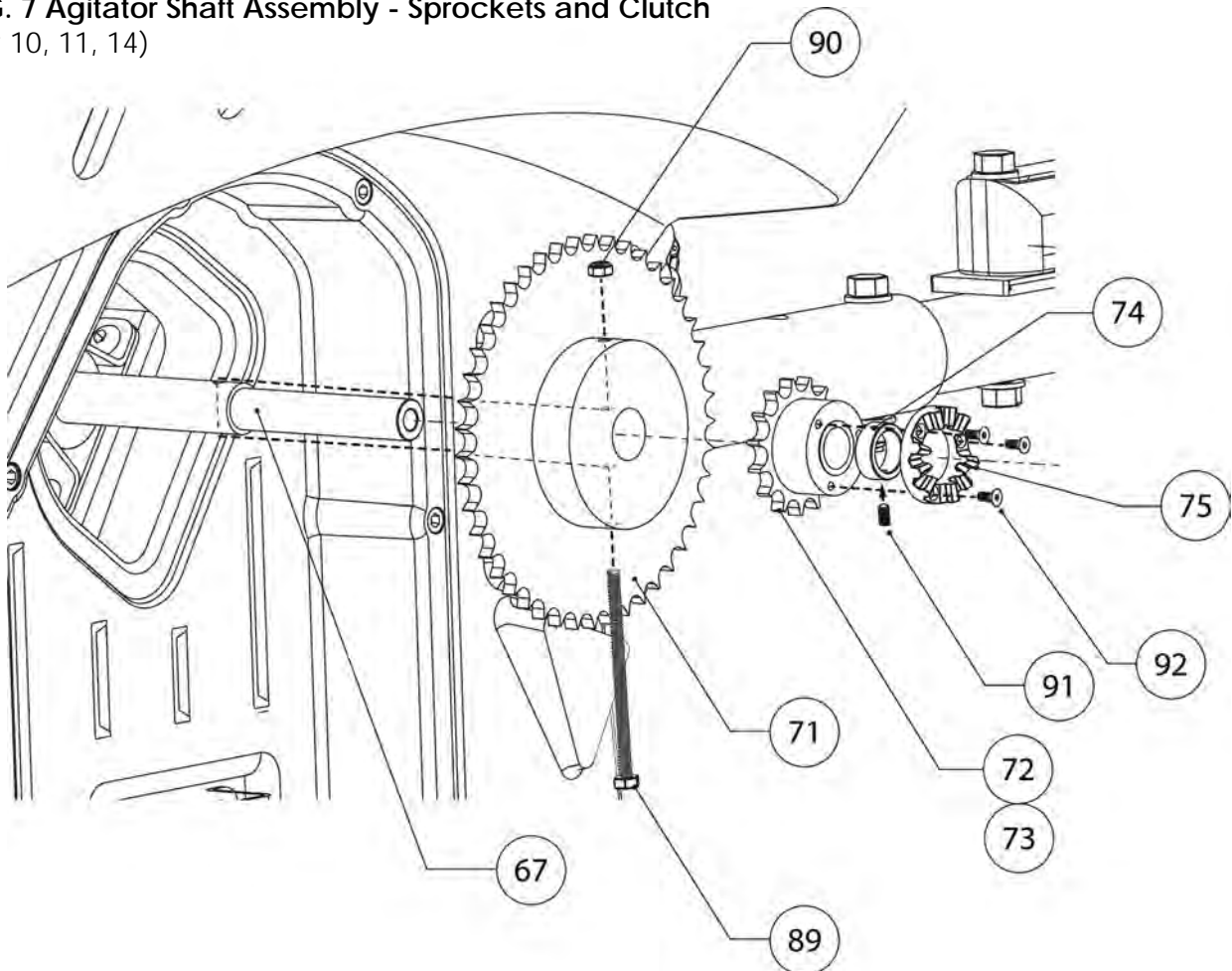

FIG. 7 Agitator Shaft Assembly - Sprockets and Clutch
(Kit 10, 11, 14)



3 Exploded Views

FIG. 8 Agitator Shaft Assembly - Cams and Bearings
(Kit 6, 7)

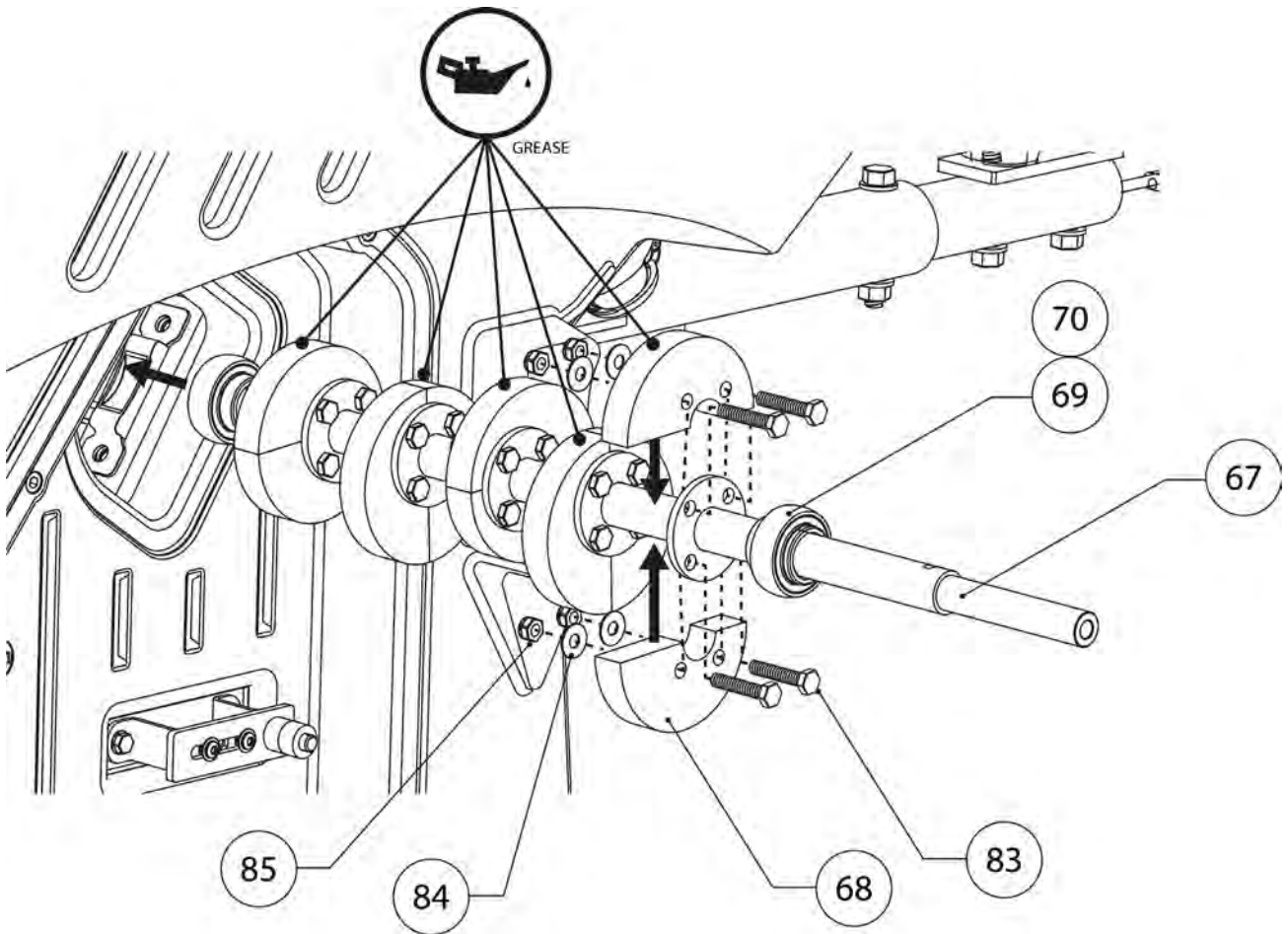
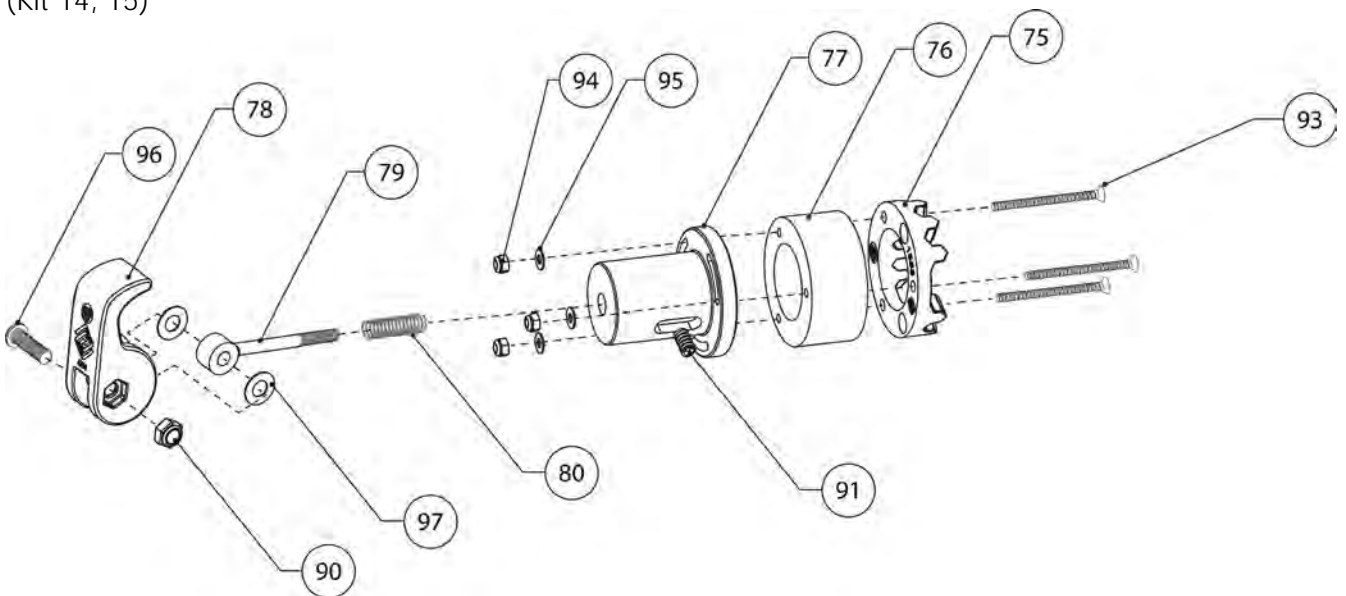

FIG. 9 Clutch and Cam Handle Assembly
(Kit 14, 15)



3 Exploded Views

FIG. 10 Spinner Plate / Spread Limiter Assembly
(Kits 16, 17, 25)

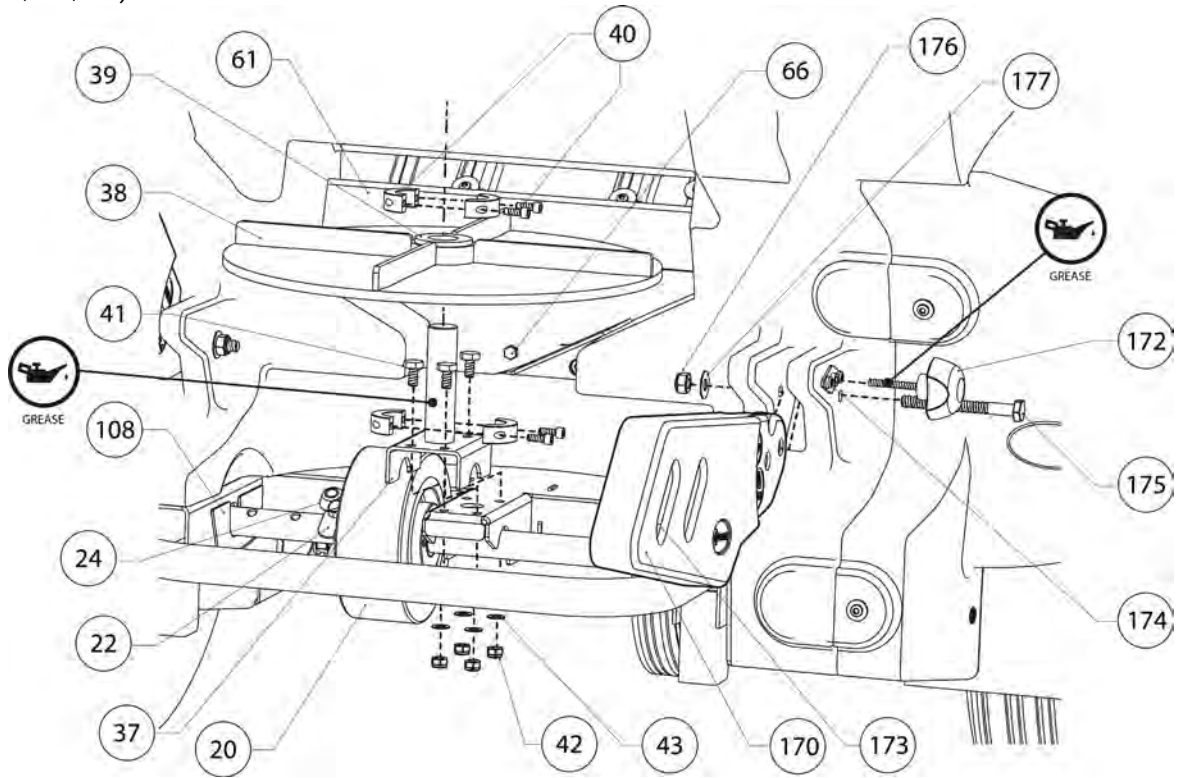
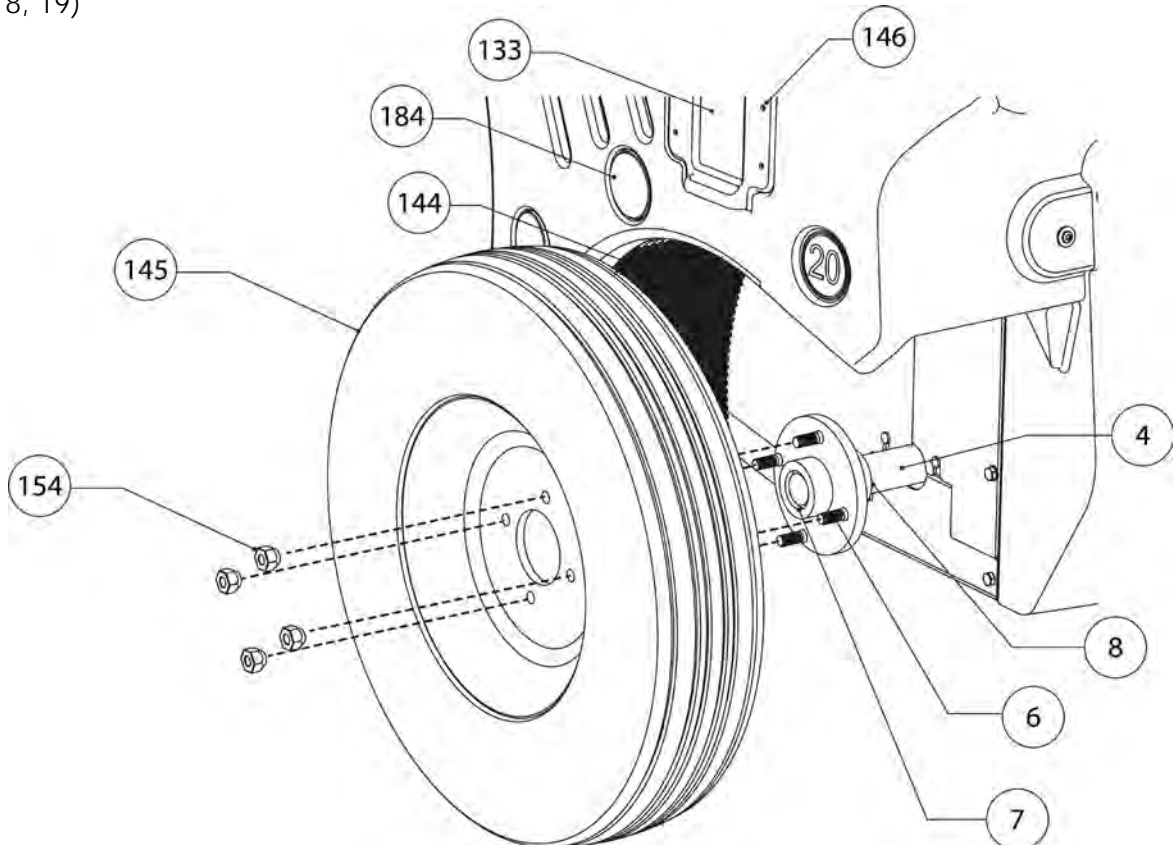

FIG. 11 Wheel and Free Hub Assembly
(Kits 18, 19)



3 Exploded Views

FIG. 12 Drive Shaft Hub Sprocket Assembly
(Kit 12)

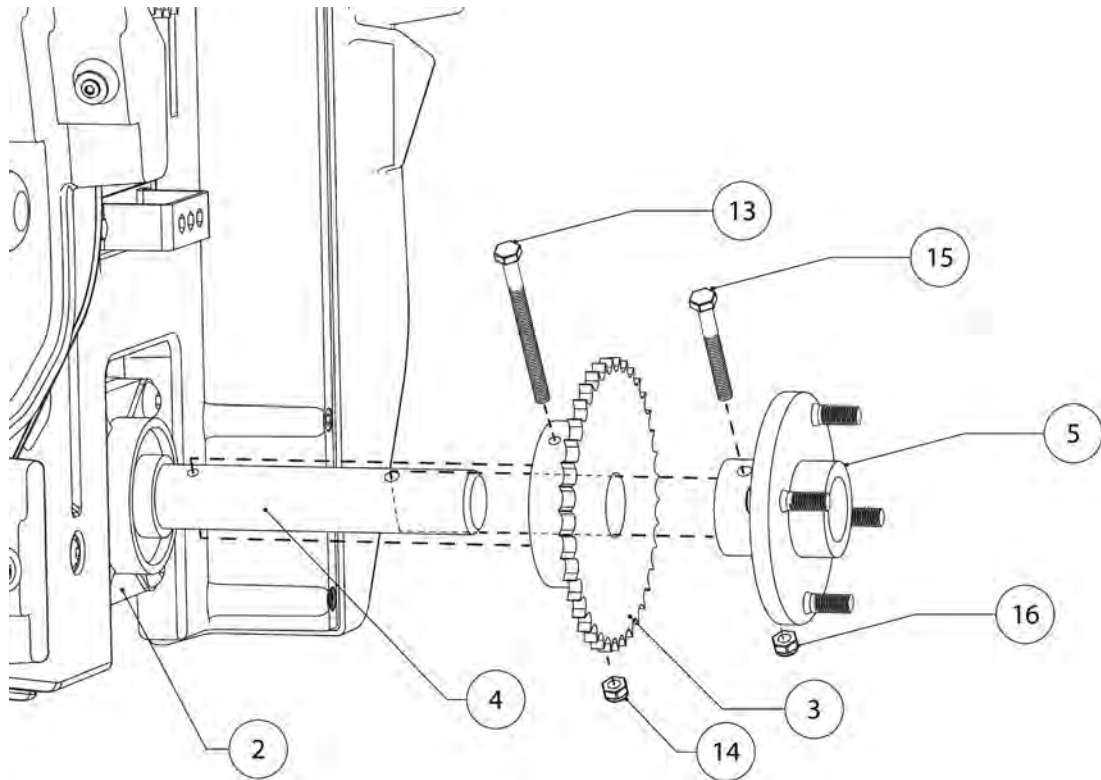
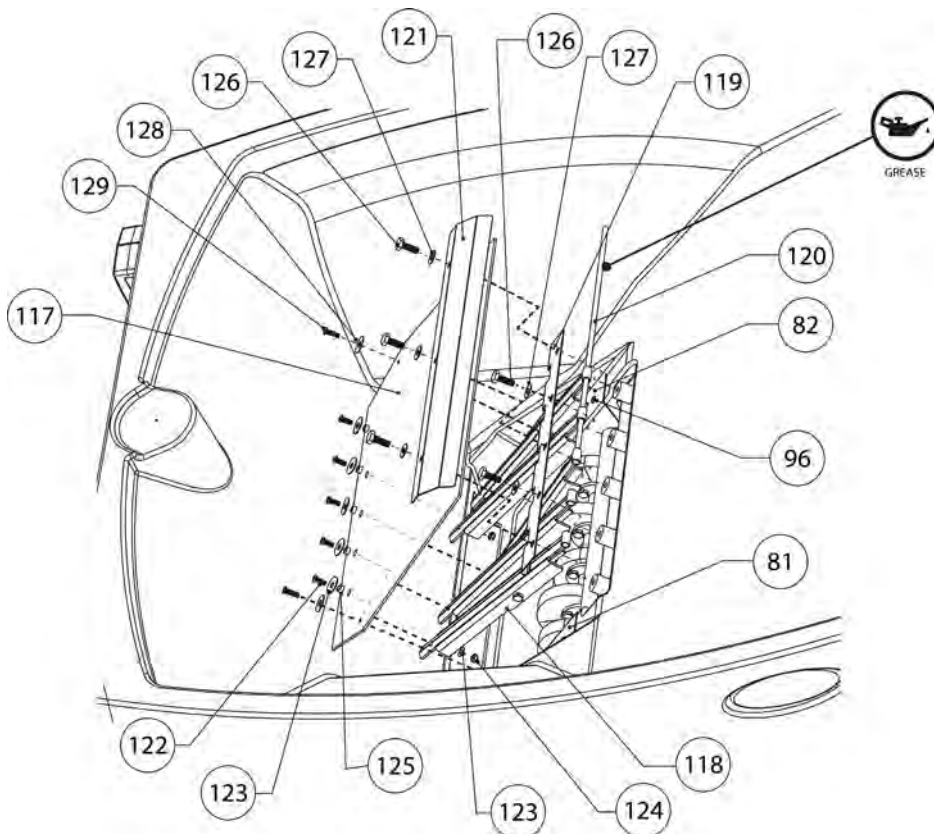

FIG. 13 Agitator Mat and Fingers Assembly
(Kit 8, 9)



3 Exploded Views

FIG. 14 Lighting Assembly
(Kit 21, 22, 23)

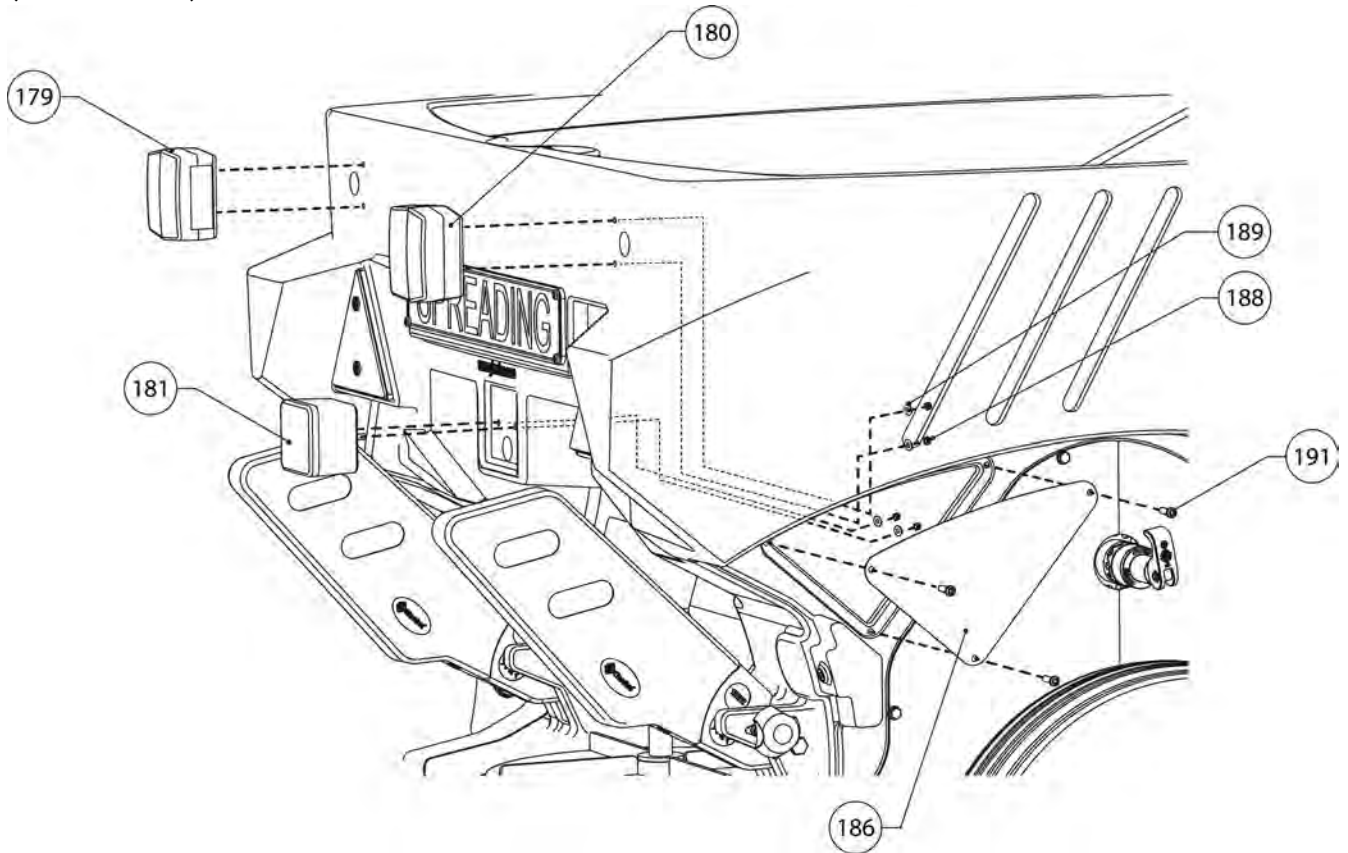
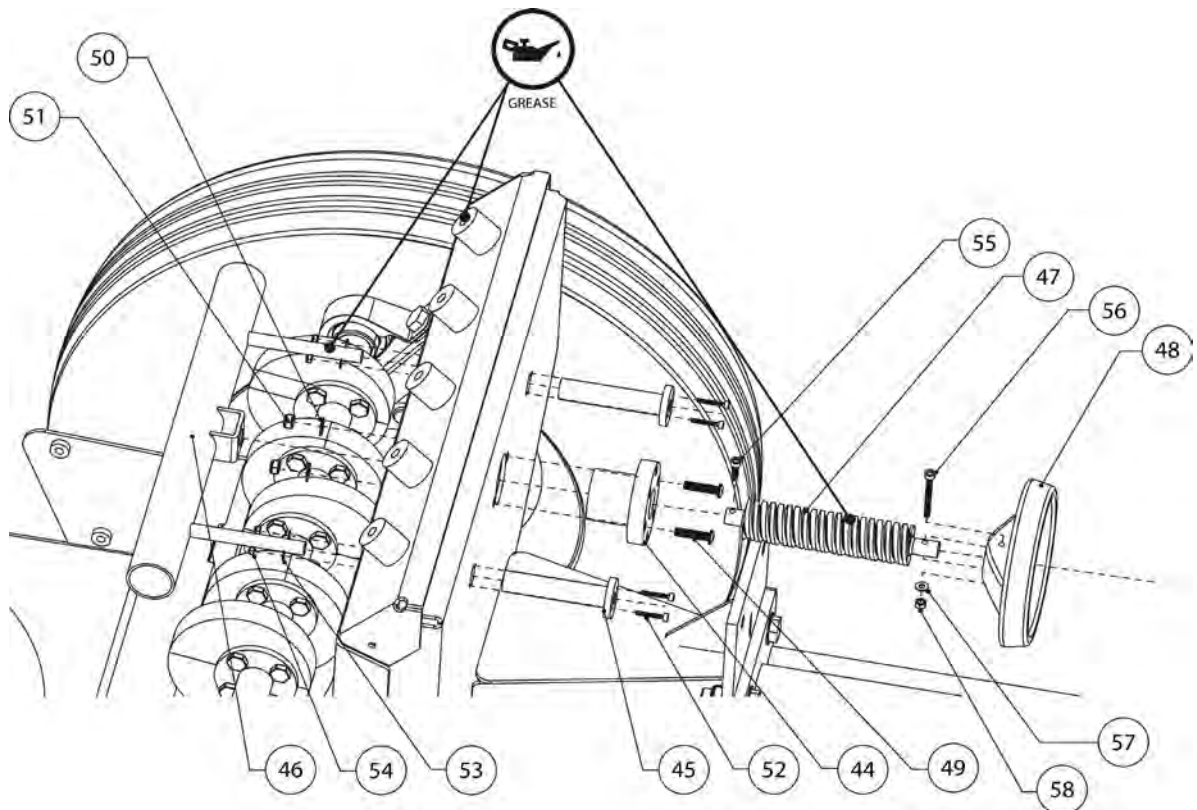

FIG. 15 Flow Control Assembly



3 Exploded Views

FIG. 16 Drive Wheel Assembly
(Kit 26)

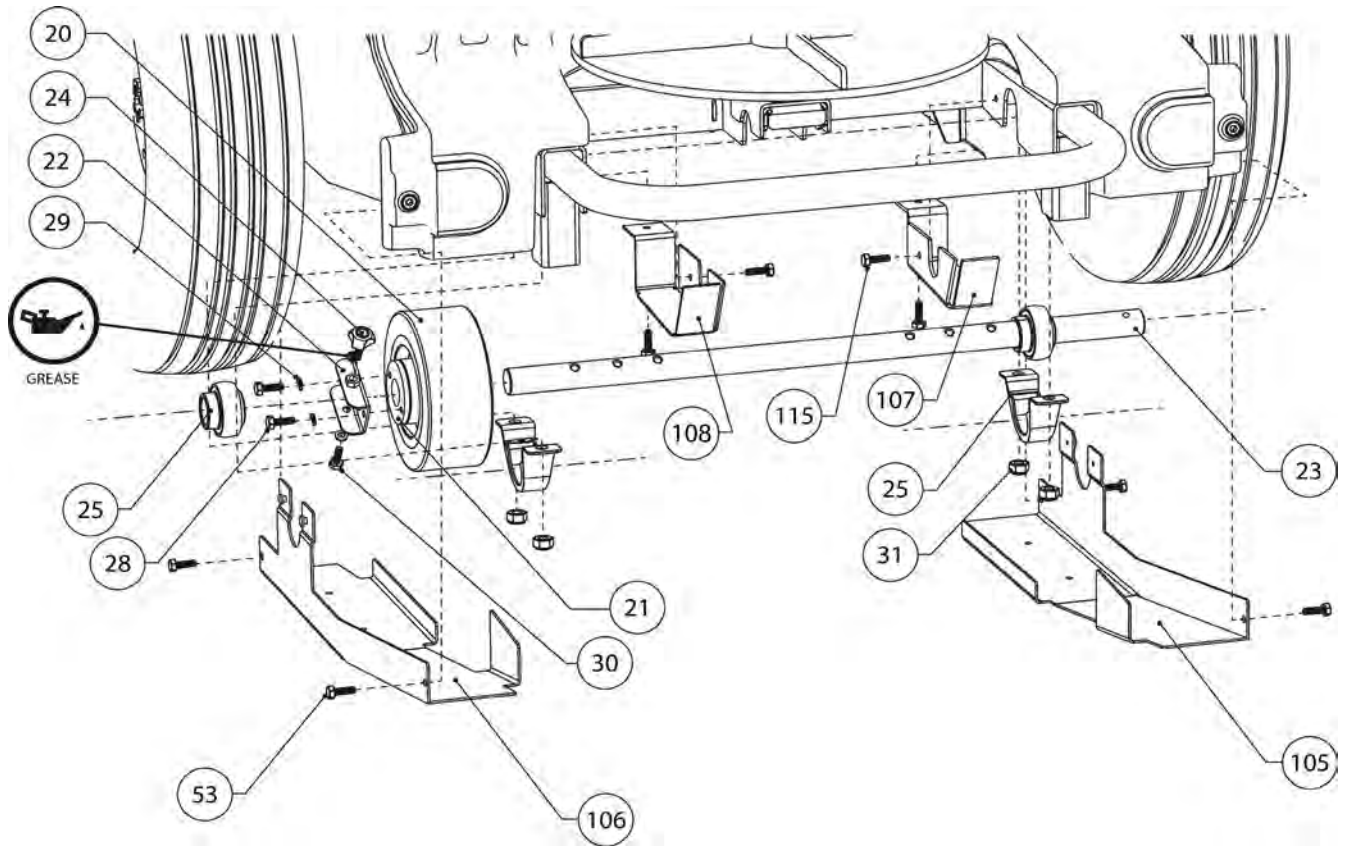

FIG. 17 Drive System

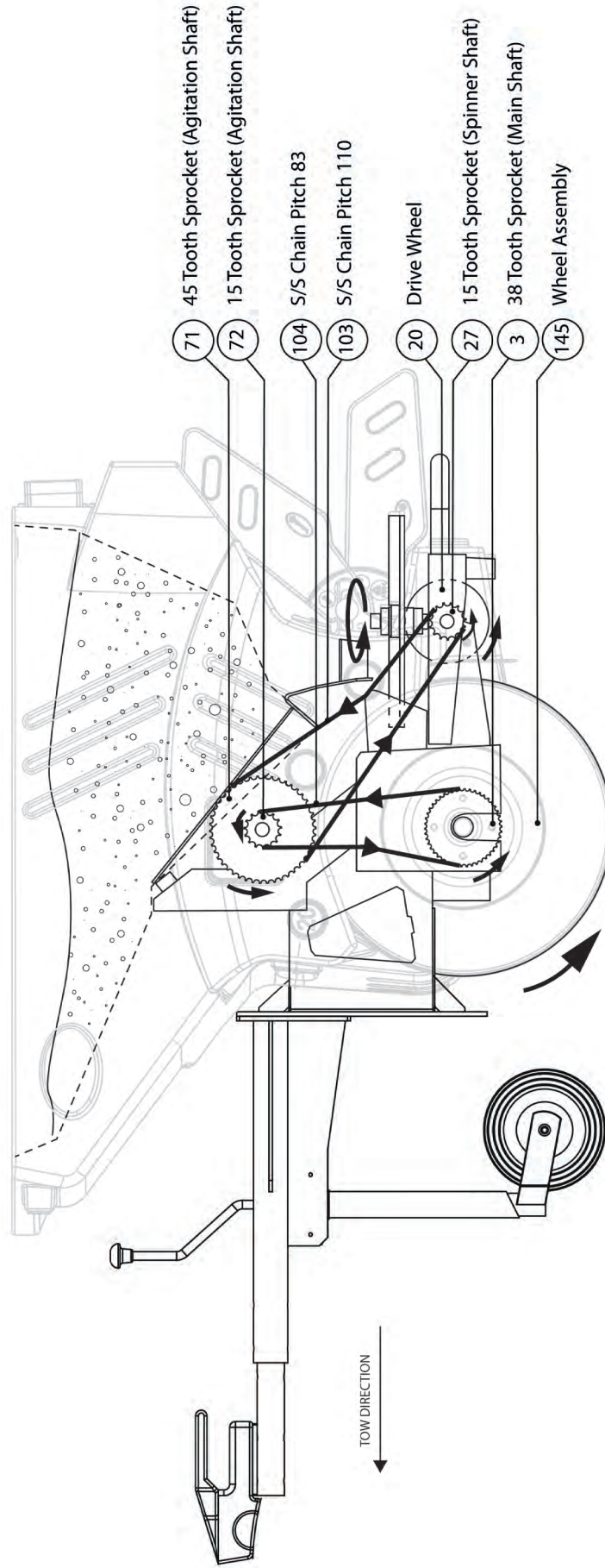

FIG. 18 Agitation System

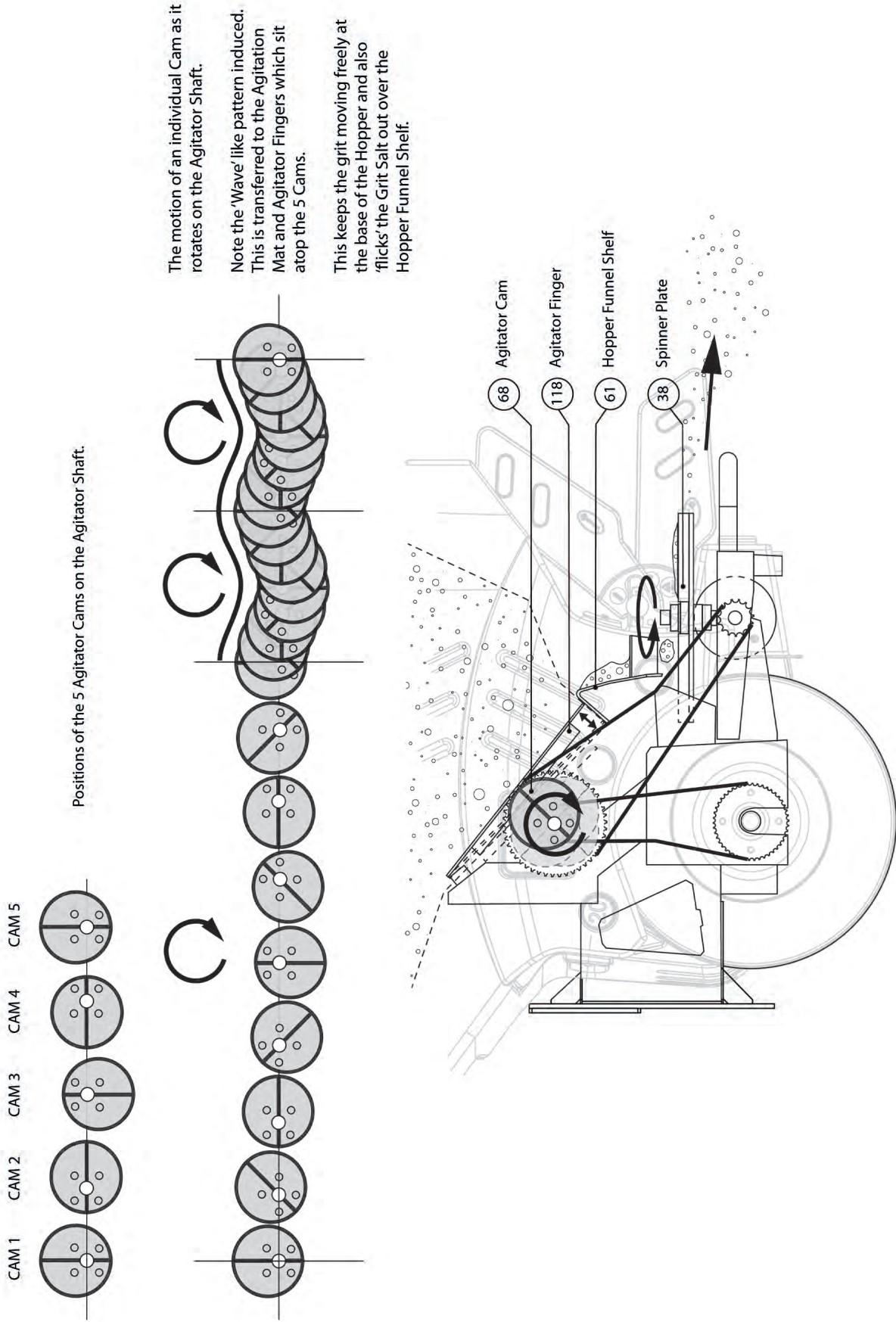
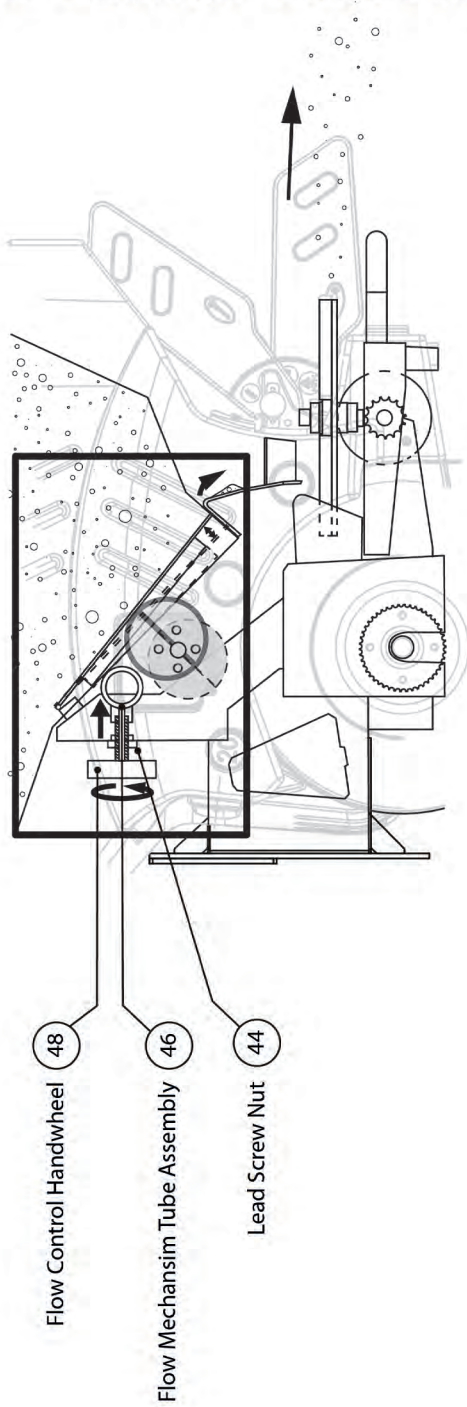

FIG. 19 Flow Control Mechanism

Rotating the Flow Control Handwheel moves the Flow Mechanism Tube Assembly inward toward the rear of the machine.

This presses the Mechanism against the underside of the 5 Agitator Fingers and so restricts the amount of displacement afforded to them - as they are raised slightly off the Agitator Cams during part of the rotation of each Cam.

When the Handwheel is turned the opposite direction this releases the Flow Control Mechanism completely from the Agitator Fingers and so the Fingers are free to oscillate up and down under the full range of motion of the Cams. More grit is therefore expelled from the Hopper on each revolution of the Agitator Shaft.



Min. Output

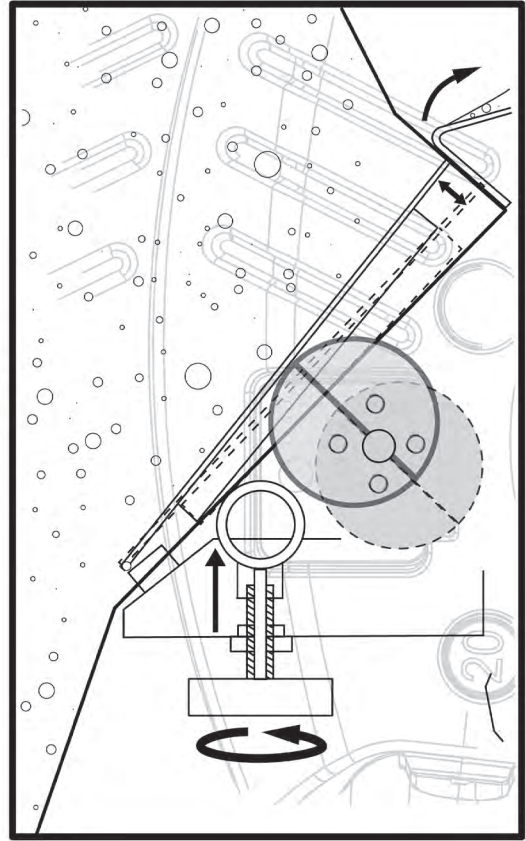

Max. Output

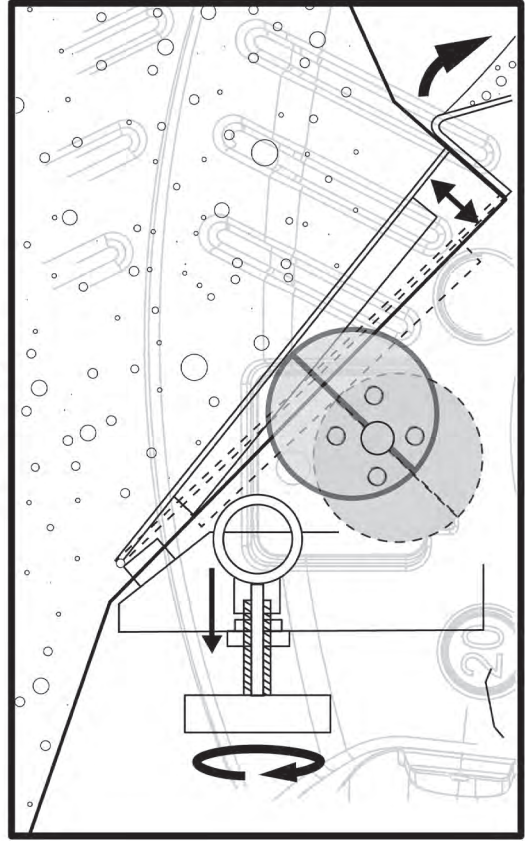



The Turbocast 800 is CE Marked, it has been designed to comply with the relevant Standards and Directives for its product classification.

An EC Declaration of Conformity certificate and a copy of the CE Marking Turbocast 800 Technical File is available from the Glasdon UK Quality Assurance Department upon request.

-
- A planned maintenance schedule of regular inspection is recommended, replacing components as necessary.
 - Replacement components are available direct from Glasdon.
 - Glasdon cannot be held responsible for claims arising from incorrect installation, unauthorised modification or misuse of the product.

Should you require any further assistance please contact us on
tel: 01253 600410, fax: 01253 792558 or email: sales@glasdon-uk.co.uk



In accordance with our policy of continuous development and improvement, we reserve the right to make changes in design and specification without notice. Glasdon UK Limited products are manufactured under license worldwide and various components of the models are patented and design registered.