

Modus 1280™

Installation Requirements

The Modus 1280 is a high capacity recycling bin housing, which securely contains a wheeled bin in a tidy manner. Modus creates a focal recycling point, ideal for areas such as housing developments, bring sites, parks and also for commercial use. Modus transforms any old/unsightly recycling containers into an attractive recycling centre.

It is not recommended that the Modus is installed directly onto tarmac or paving.

For all Modus siting, a concrete base is required to produce a level, flat and secure foundation. Below are the concrete base and fixing requirements for the **Modus 1280**:

Dimensions for the concrete base must be a minimum of:

- 200mm thickness of concrete
- 1900mm in width
- 2200mm in depth

This will allow adequate space for fixing bolts around the Modus and enough distance in front of the unit for a smooth door operation.

- **4 holes** to be drilled for ground fixing bolts (**holes = 10mm X 150mm** see installation instructions).
- **All holes** must be between **100mm** and **150mm** away from the edge of the concrete to provide a secure ground fixing.

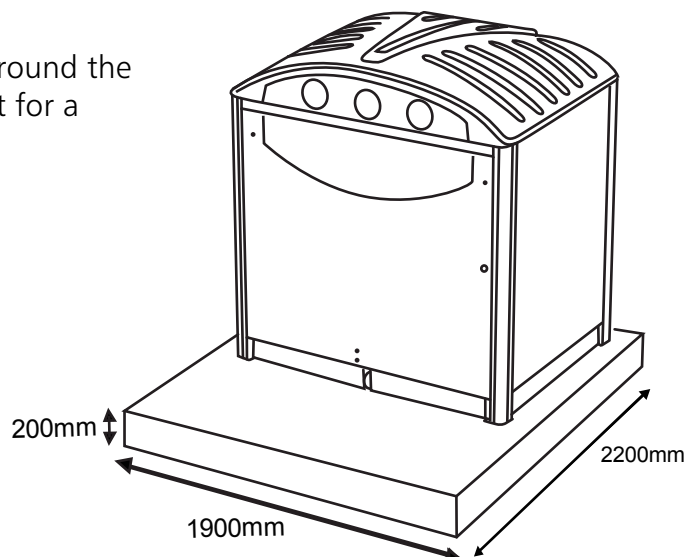

We recommend that a risk assessment is undertaken to identify an appropriate location for your waste collection and recycling units. In order to reduce risk, some organisations decide to place the units **a minimum of 5 meters away from buildings**. Any potential risk can be further reduced by maintaining a regime of regularly emptying the unit. You may also wish to consider installing a Glasdon Firesafe. Glasdon Firesafe is an effective low cost auxiliary device designed to quickly extinguish fire at source but is not intended to replace primary fire prevention measures.

• A planned maintenance schedule or regular inspection is recommended, replacing components as necessary.

• Replacement components are available direct from GLASDON.

• GLASDON cannot be held responsible for claims arising from incorrect installation, unauthorised modifications or misuse of the product.

© Copyright 2012

Glasdon UK Ltd reserve the right to alter specifications without prior notice.



Preston New Road
Blackpool
Lancashire
FY4 4UL

Tel: 01253 600410
Fax: 01253 792558
e-mail: sales@glasdon-uk.co.uk
web: www.glasdon.com