

# PEMBRIDGE™ PICNIC TABLE

## INSTRUCTIONS MANUAL

**IMPORTANT NOTE:** ENSURE THAT ALL RELEVANT PERSONNEL READ THESE INSTRUCTIONS PRIOR TO USE

Please also refer to the 'Manual Handling Operations Regulations 1992' during the handling of the product and materials used for installation. Glasdon recommends that a full Health and Safety analysis is carried out prior to installation.

**Standard model**

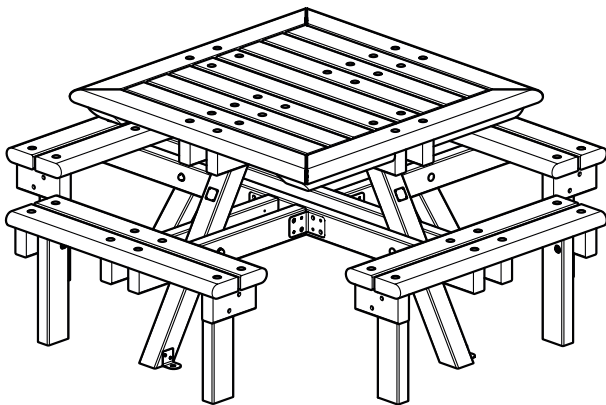

**Wheelchair Access model**

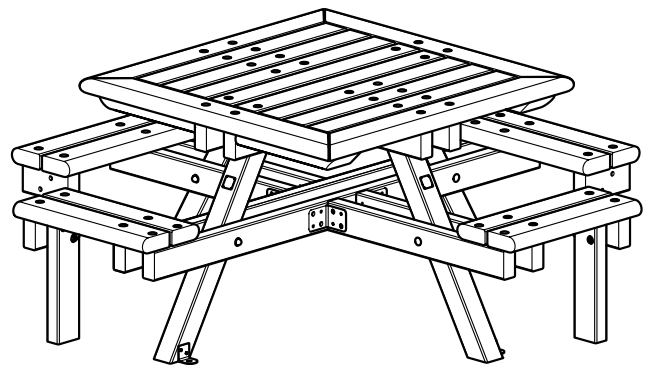

### KIT CONTENTS:

<b>Table Pack (Main Assembly)</b>	<b>x 1</b>
<b>ITEM 1</b> - Short Crossbar and Leg Assembly	x 2
<b>ITEM 2</b> - Seat Assembly	x 2
<b>ITEM 3</b> - Screw - M5 x 30mm - T-Star	x 8
<b>ITEM 4</b> - Coach Bolt - M10 x 180mm	x 2
<b>ITEM 5</b> - Washer - M12 x Ø23mm	x 10
<b>ITEM 6</b> - Nyloc Nut - M10	x 10
<b>ITEM 7</b> - Domed Tamper Resistant Cover Cap	x 4
<b>ITEM 8</b> - Tamper Resistant Cover Cap	x 8
<b>ITEM 9</b> - Hex Head Bolt - M10 x 130mm	x 8

### EQUIPMENT REQUIRED:

- Cordless Drill (or Screwdriver) with T-Star Driver Bit	x 1
- 17mm Socket Wrench	x 2
- Mallet	x 1

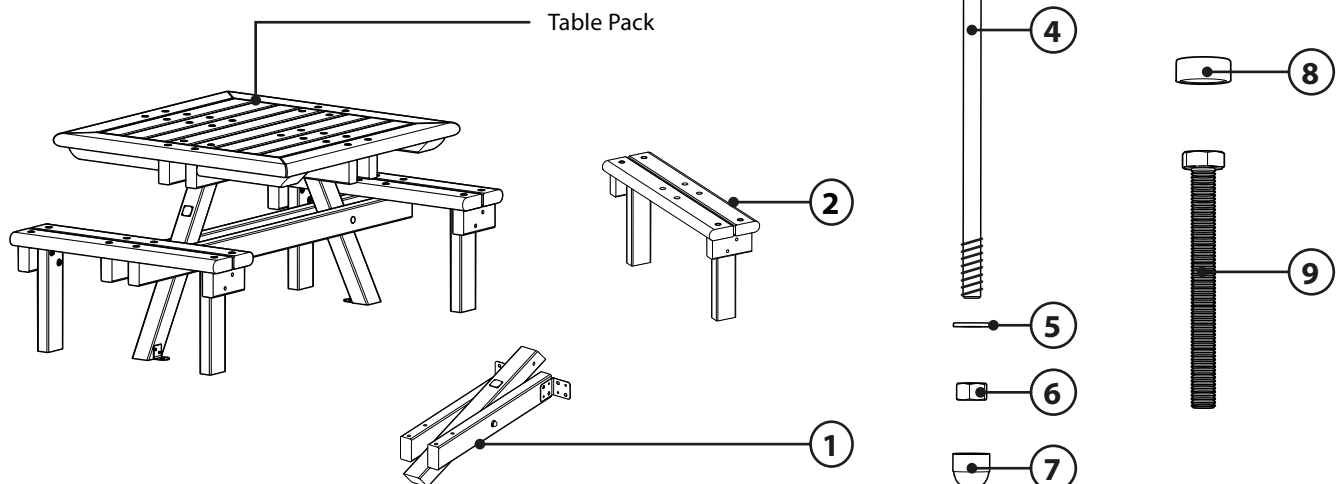

## ASSEMBLY INSTRUCTIONS

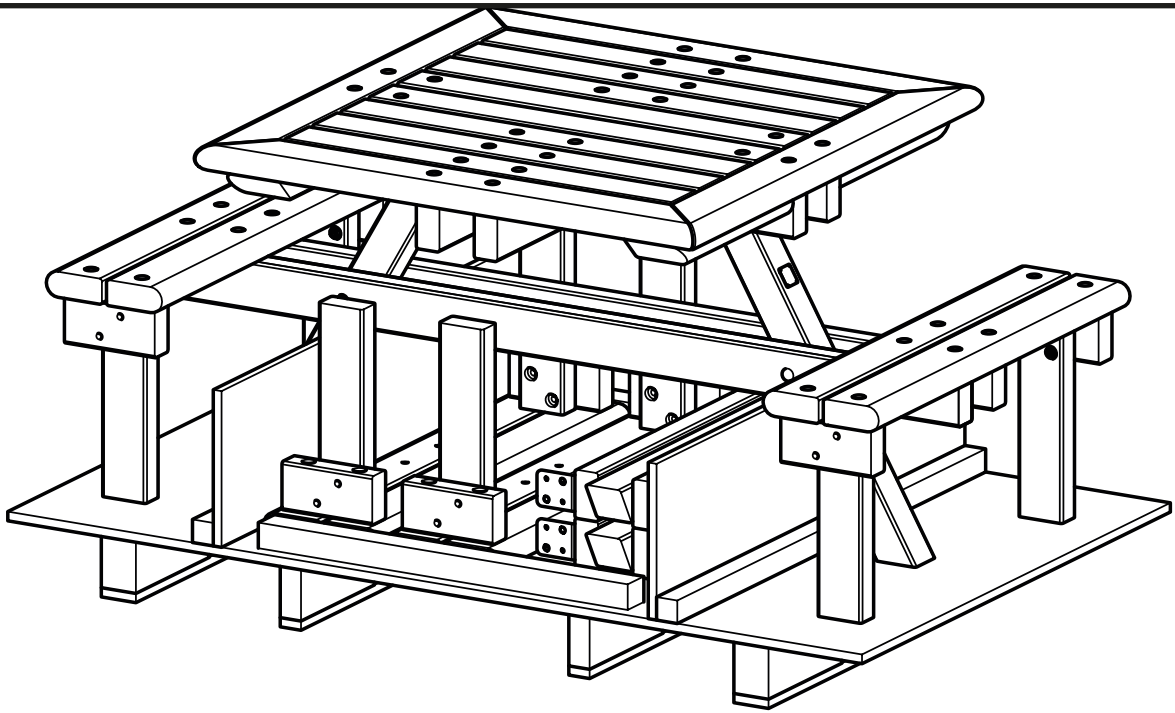

1. Carefully remove packaging from the table and pallet.

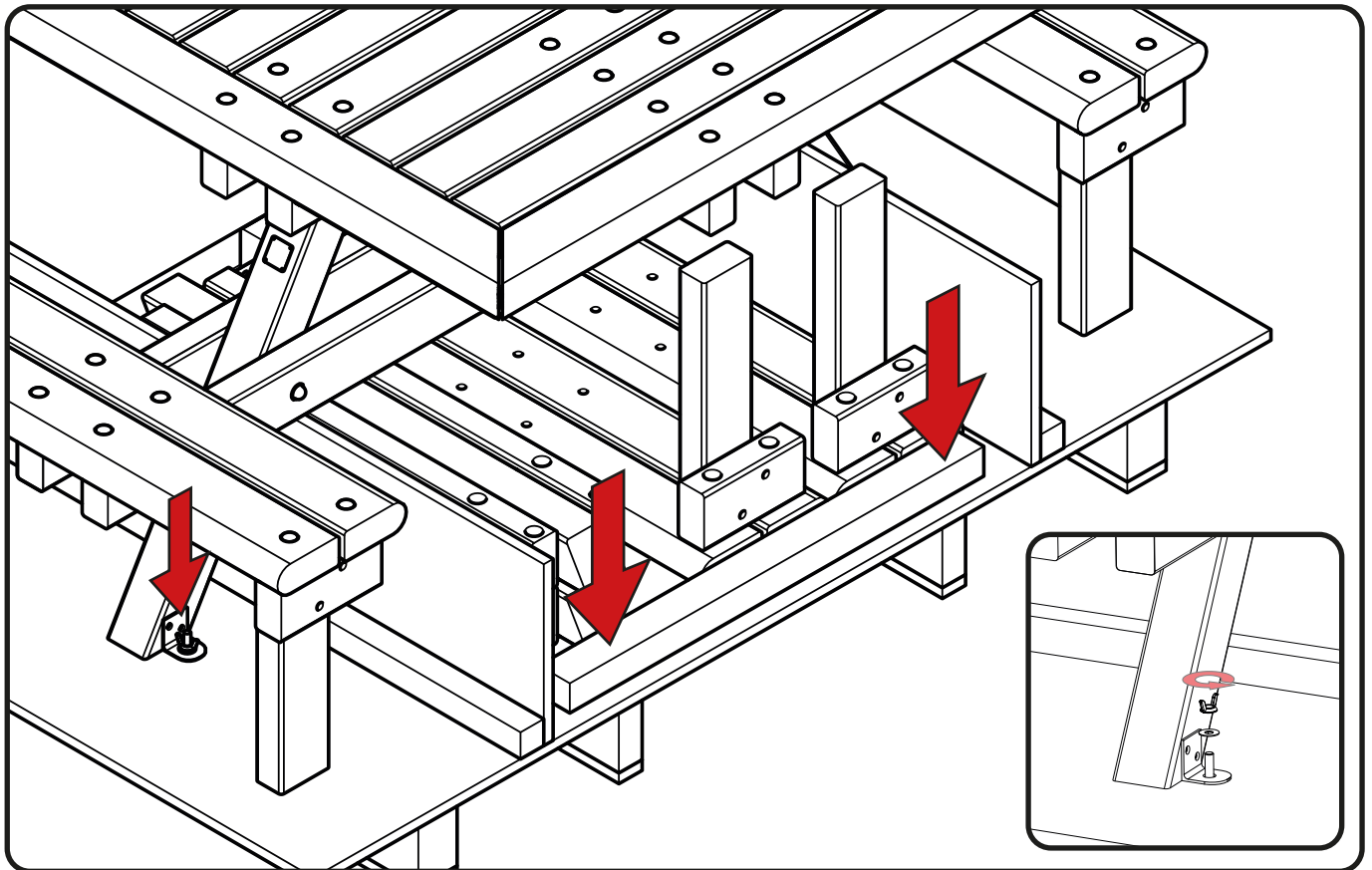

2. Using the hand drill (fitted with driver bit) or screwdriver unscrew the screws holding the timber blocks supporting the seat assemblies during transit. Remove the 2 x wingnuts holding the table legs to the pallet through the ground fixing points.

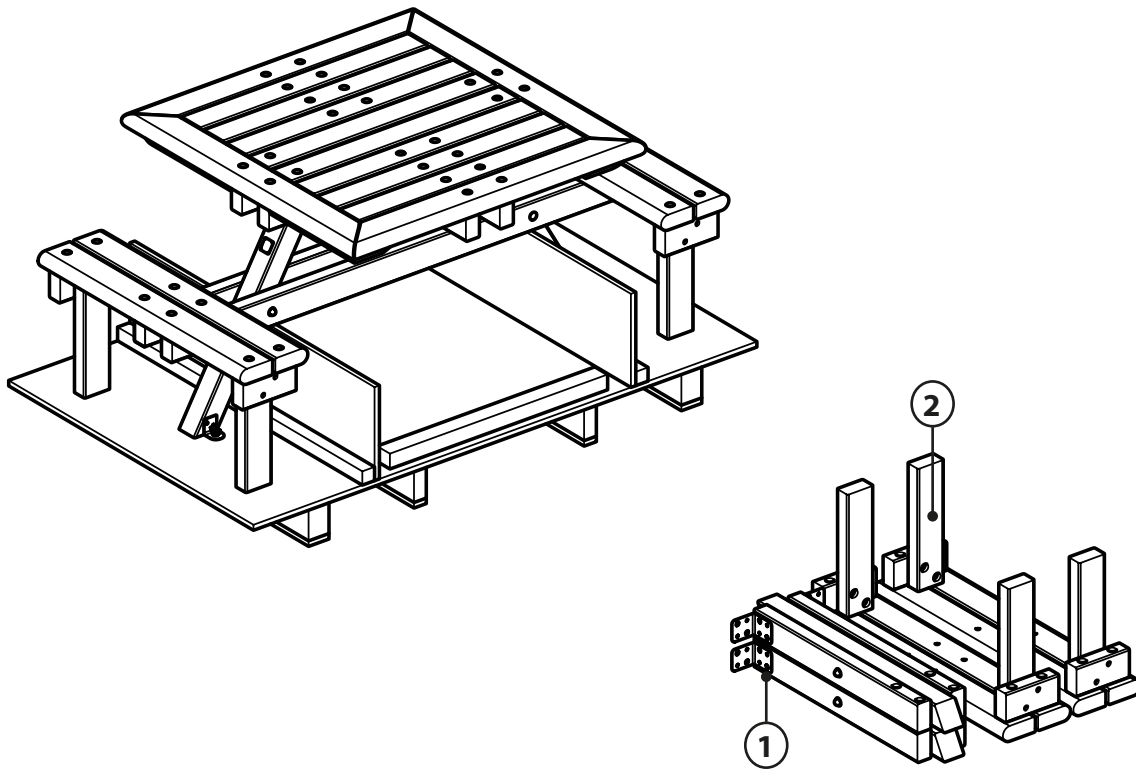

3. Carefully remove the crossbar and leg assembly (ITEM 1), seat assemblies (ITEM 2) and fixing pack from the pallet.

**IMPORTANT :**

If manually moving the table pack we strongly recommend that for the Enviropol® model a minimum of five people manoeuvre the table into position. For the Timberpol® model we recommend six people.

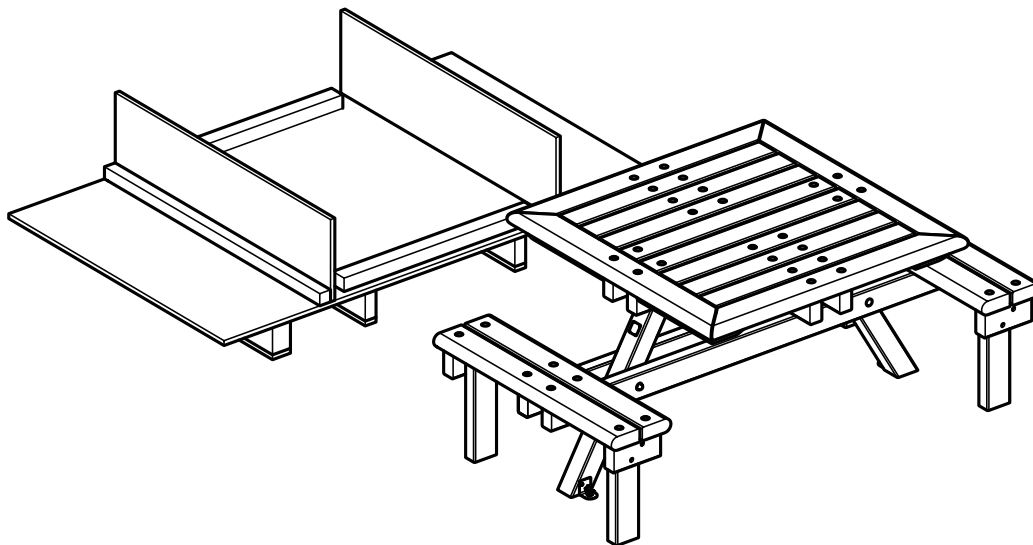

4. Carefully manoeuvre the picnic table to the desired location by lifting the table from the positions marked in the illustration above.

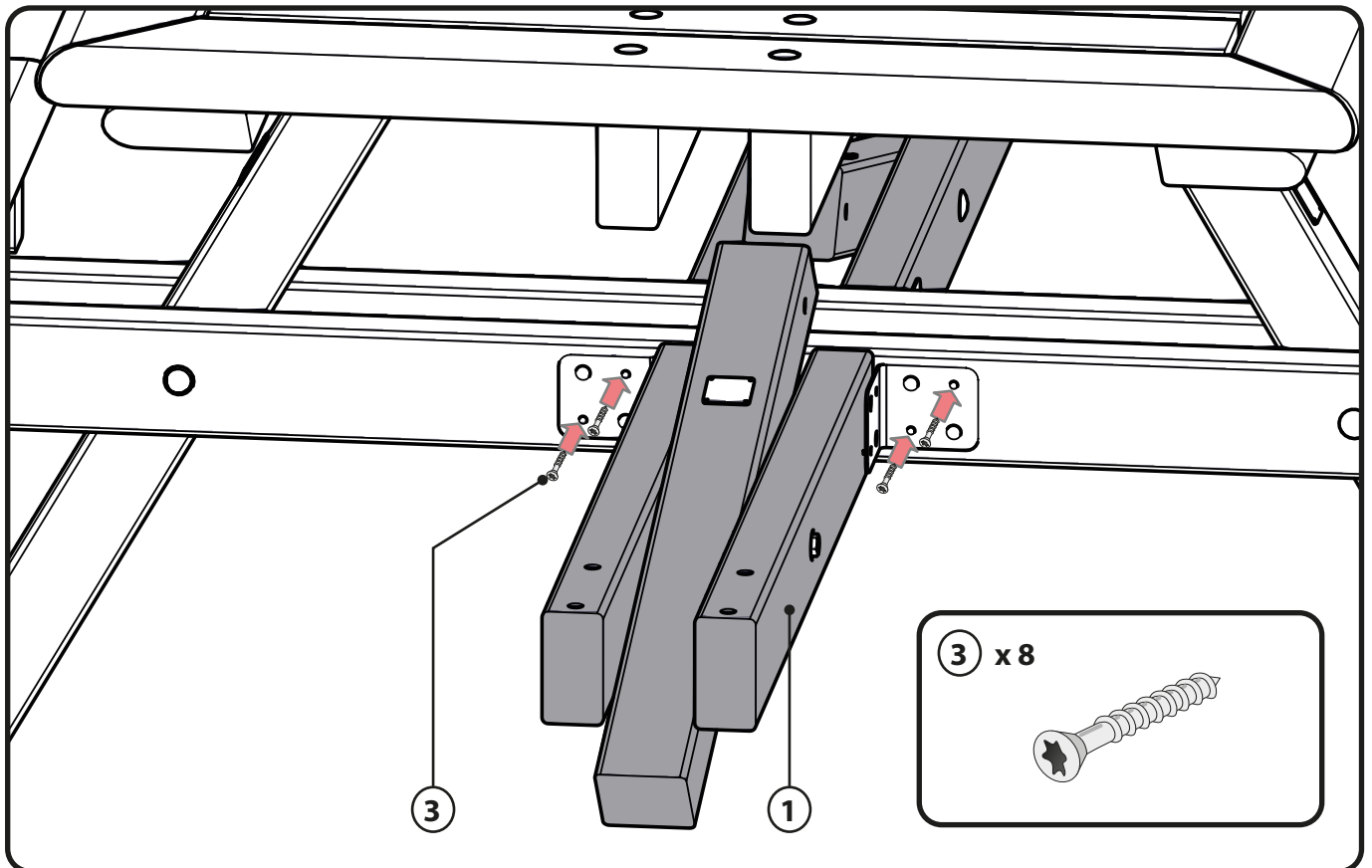

5. Attach the 2 x short crossbar and leg assembly (ITEM 1) to the fitted long crossbar using 8 x wood screws (ITEM 3) provided (2 x per bracket, 4 x per assembly).

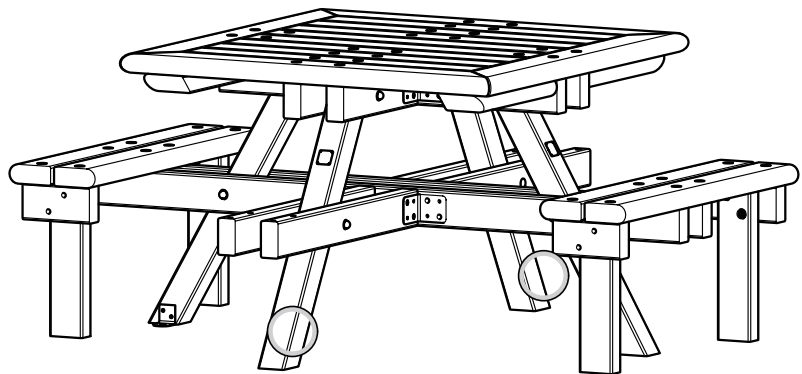
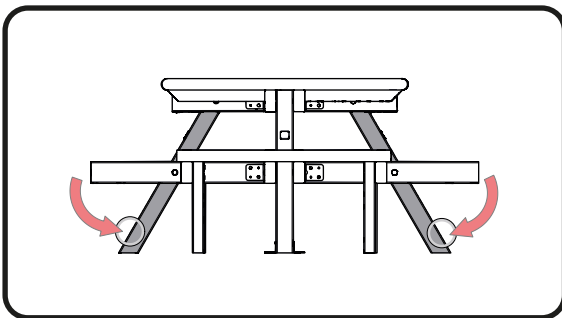

6. Pivot the legs downward until the base of each leg rests on the floor.

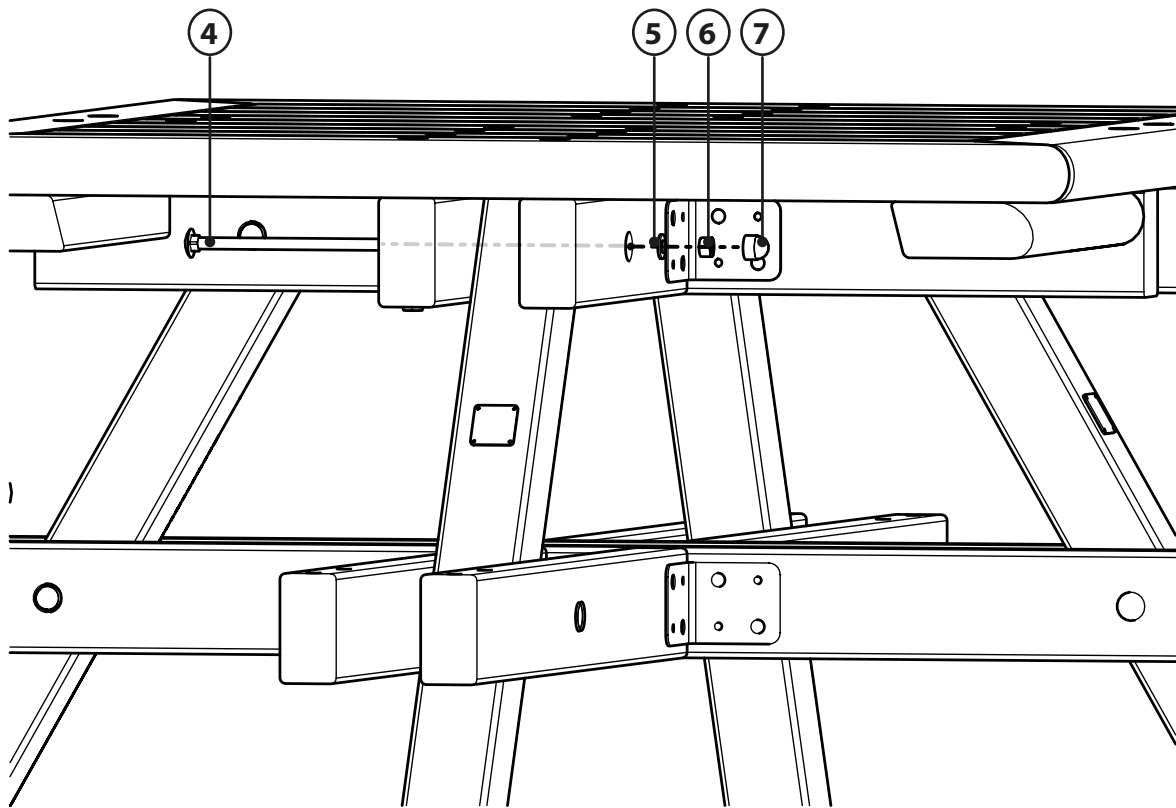

7. Insert the M10 x 180mm coach bolt (ITEM 4) through the table top support and the tops of the legs. Insert the fixing through the small hole and not the larger counter bore hole. Secure with a washer (ITEM 5) and nyloc nut (ITEM 6). Use a 17mm socket wrench to tighten each nut. Place the cover cap (ITEM 7) over the nut.

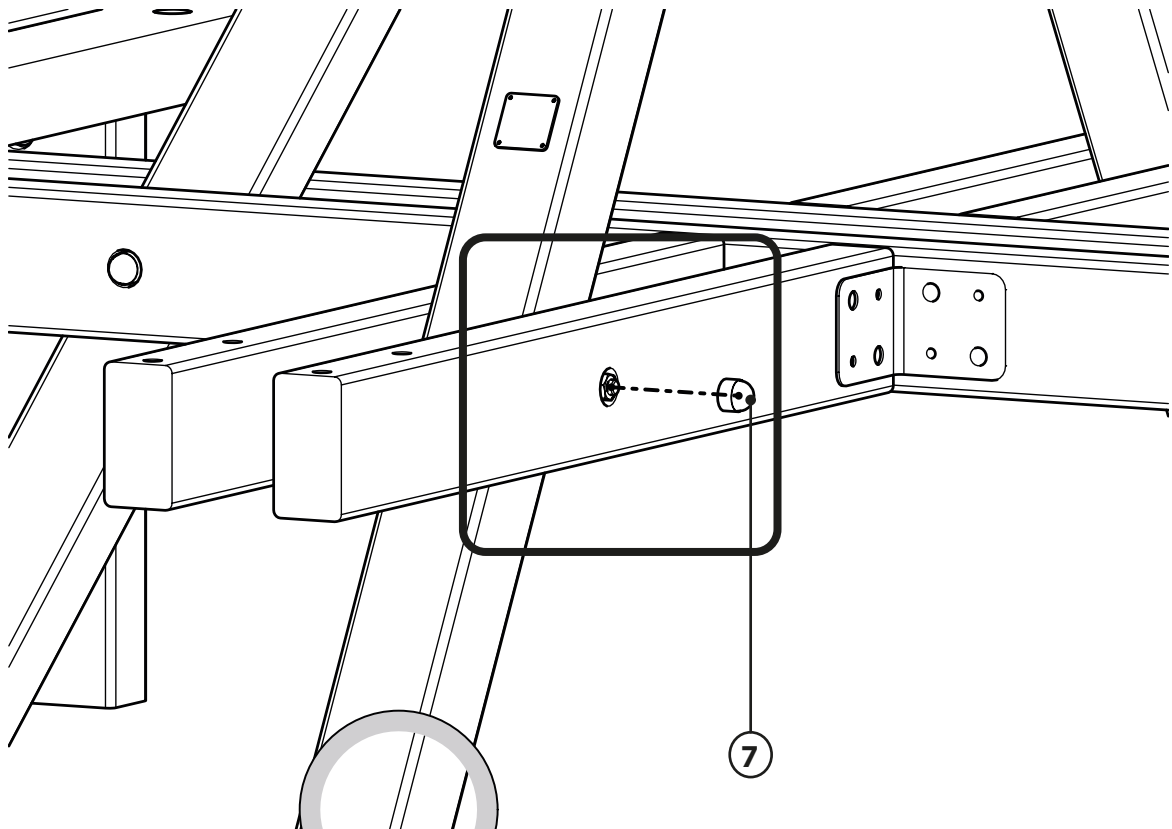

8. Tighten the fixings at the midpoint of the leg assembly using the 17mm socket wrench. Fit the cover cap (ITEM 7) in place over the nut. Repeat for the opposite leg assembly.

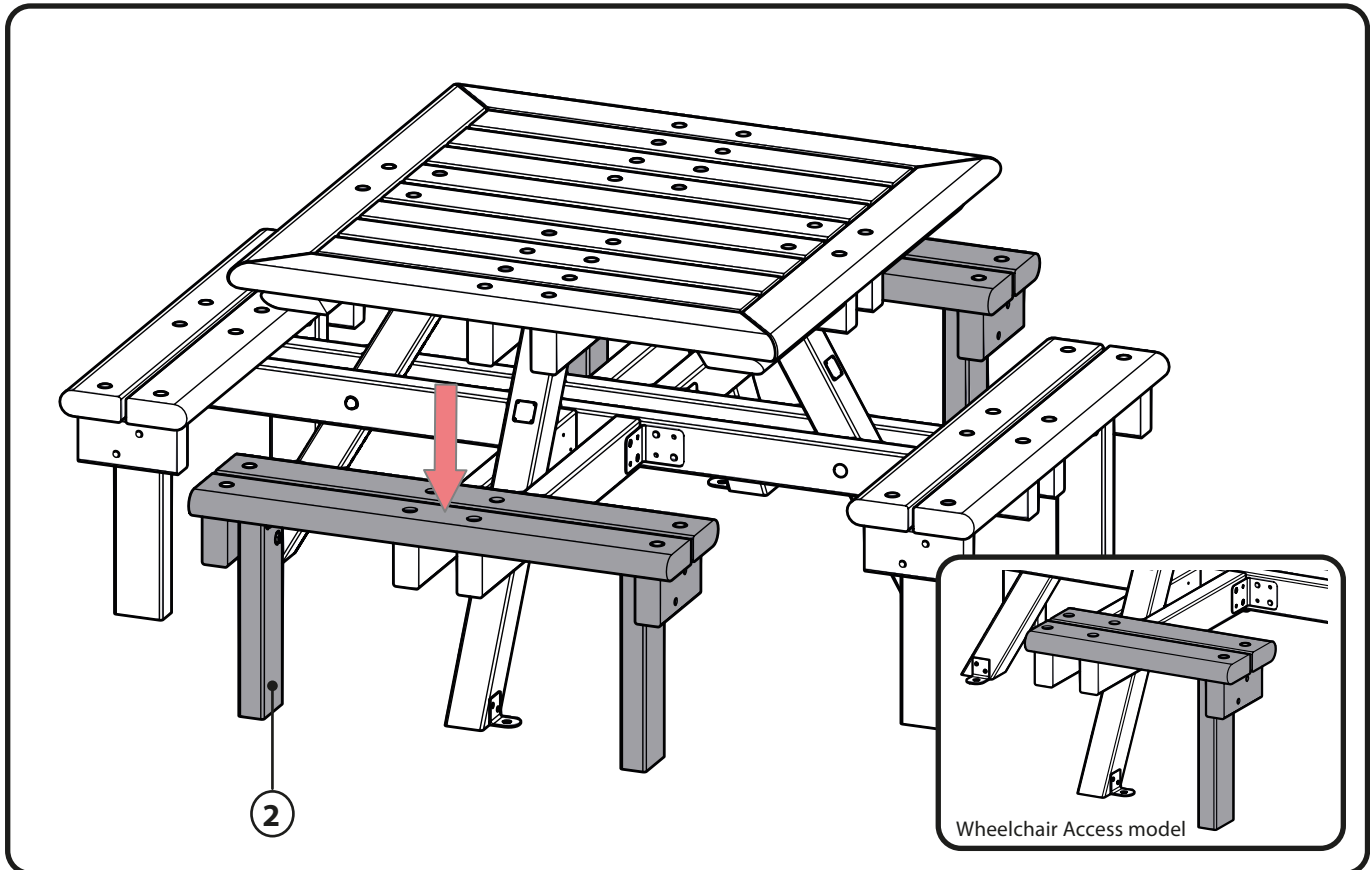

9. Place the seat assembly (ITEM 2) into position as shown. Align the four holes in the seat with the holes on the ends of the crossbar and leg assembly.

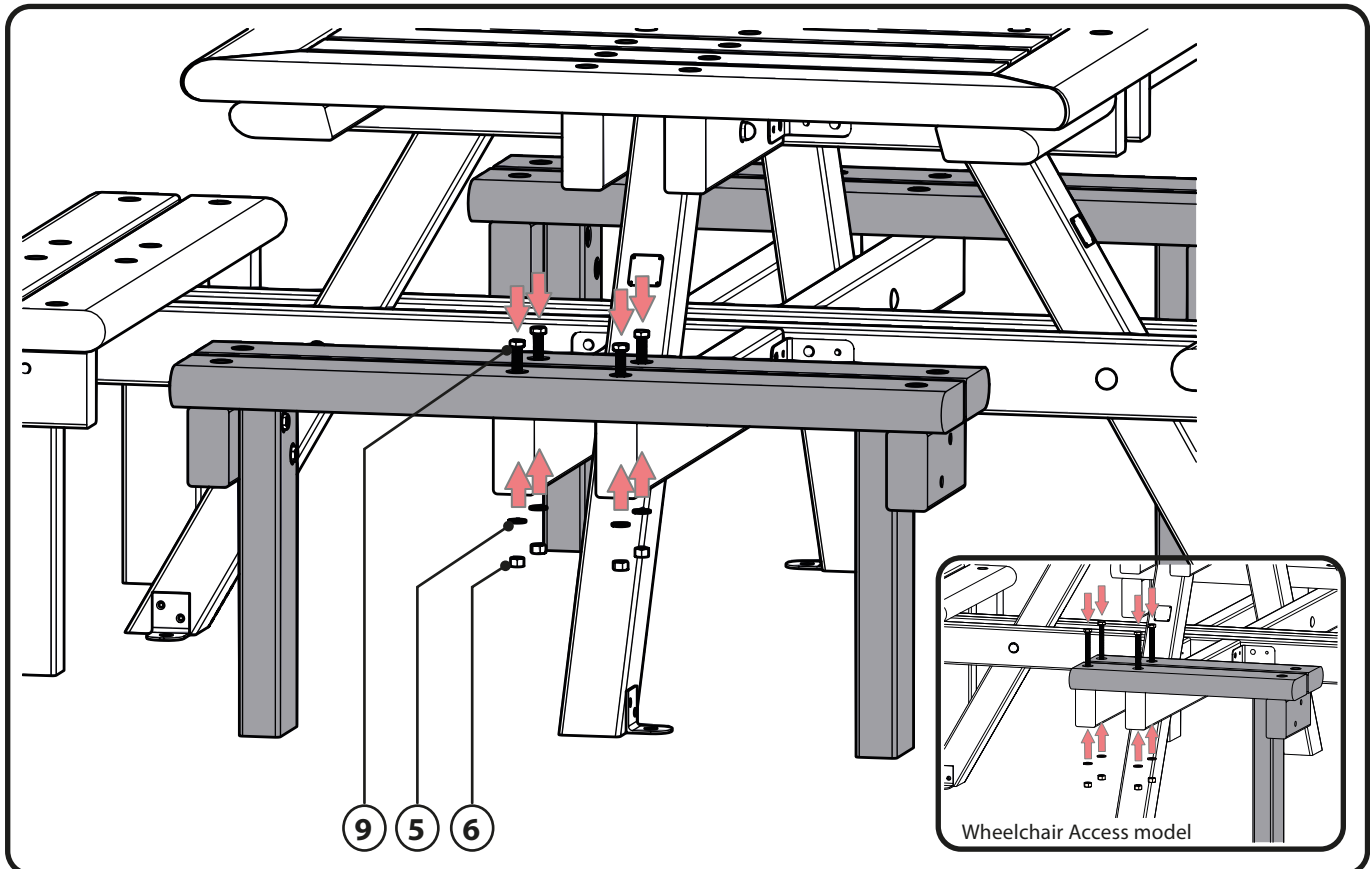

10. Insert 4 x M10 x 130mm bolts (ITEM 9) through the seat and crossbar (mallet may be required). Secure in position using the washer (ITEM 5) and nyloc nuts (ITEM 6) on the underside. Use 2 x 17mm socket wrenches to tighten all fixings. Repeat the process for the seat opposite.

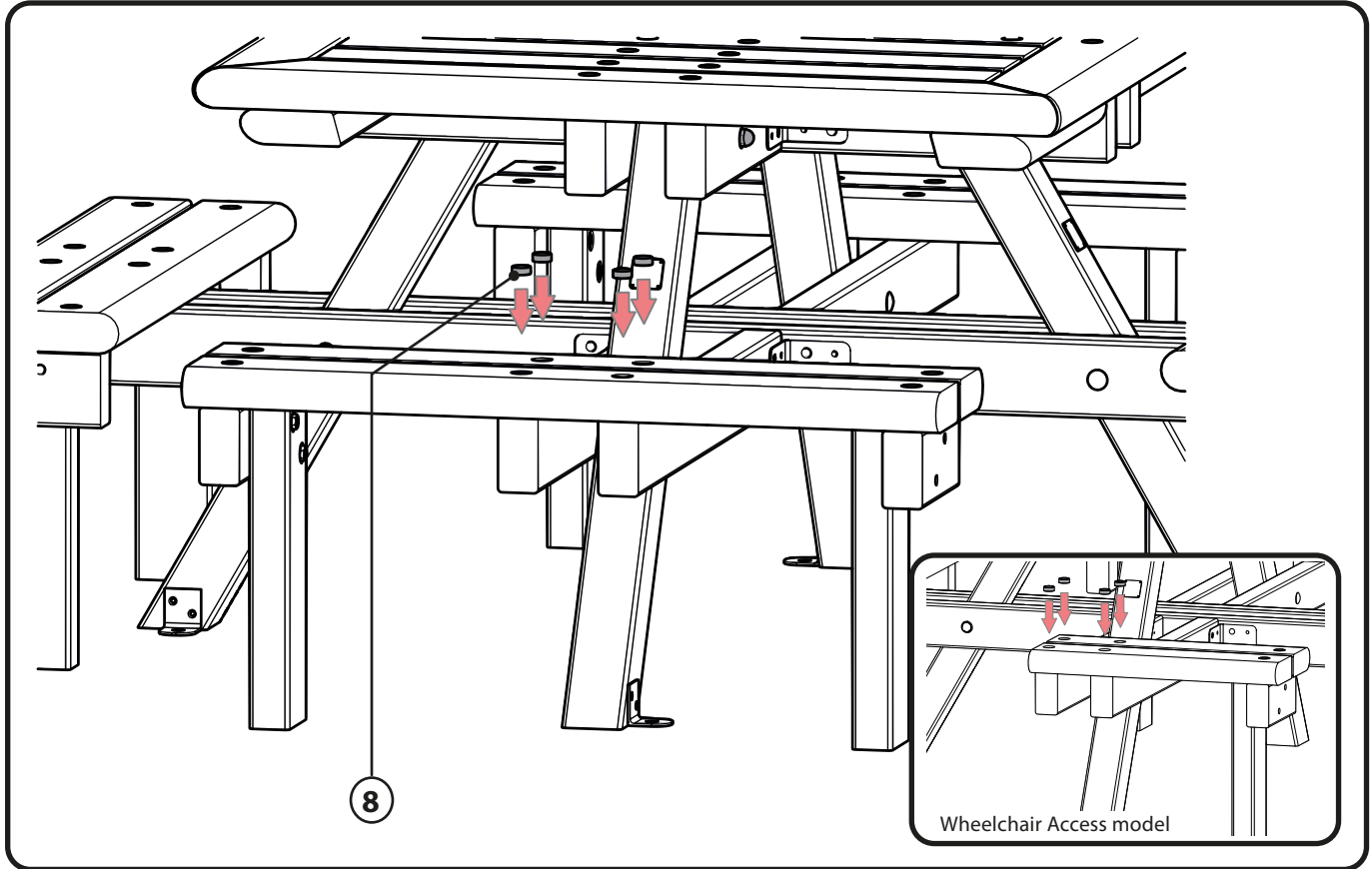

11. Fit the push-on tamper resistant cover cap (ITEM 8) on to the seat fixings (mallet may be required).  
ASSEMBLY COMPLETE.

## INSTALLATION INSTRUCTIONS

### KIT CONTENTS:

- ITEM 10 - Self Tapping Anchor Bolt - M10 x 100mm x 4  
ITEM 11 - Washer - M12 x 23mm x 4

### EQUIPMENT REQUIRED:

- Rotary Hammer Drill x 1  
- 10mm Masonry Drill Bit x 1  
- 17mm Socket Wrench x 1  
- Dust Blower/Hard Bristle Brush x 1

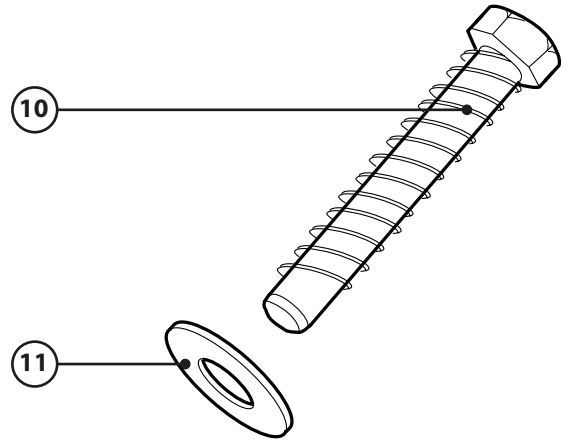

### MINIMUM BASE REQUIREMENT

If no suitable existing base, then base to be sized as per dimensions below with 200mm thickness of concrete onto well consolidated hardcore.

Base to be smooth (float finish), flat level and square and preferably flush with surrounding ground level.

### VIEW A - STANDARD MODEL

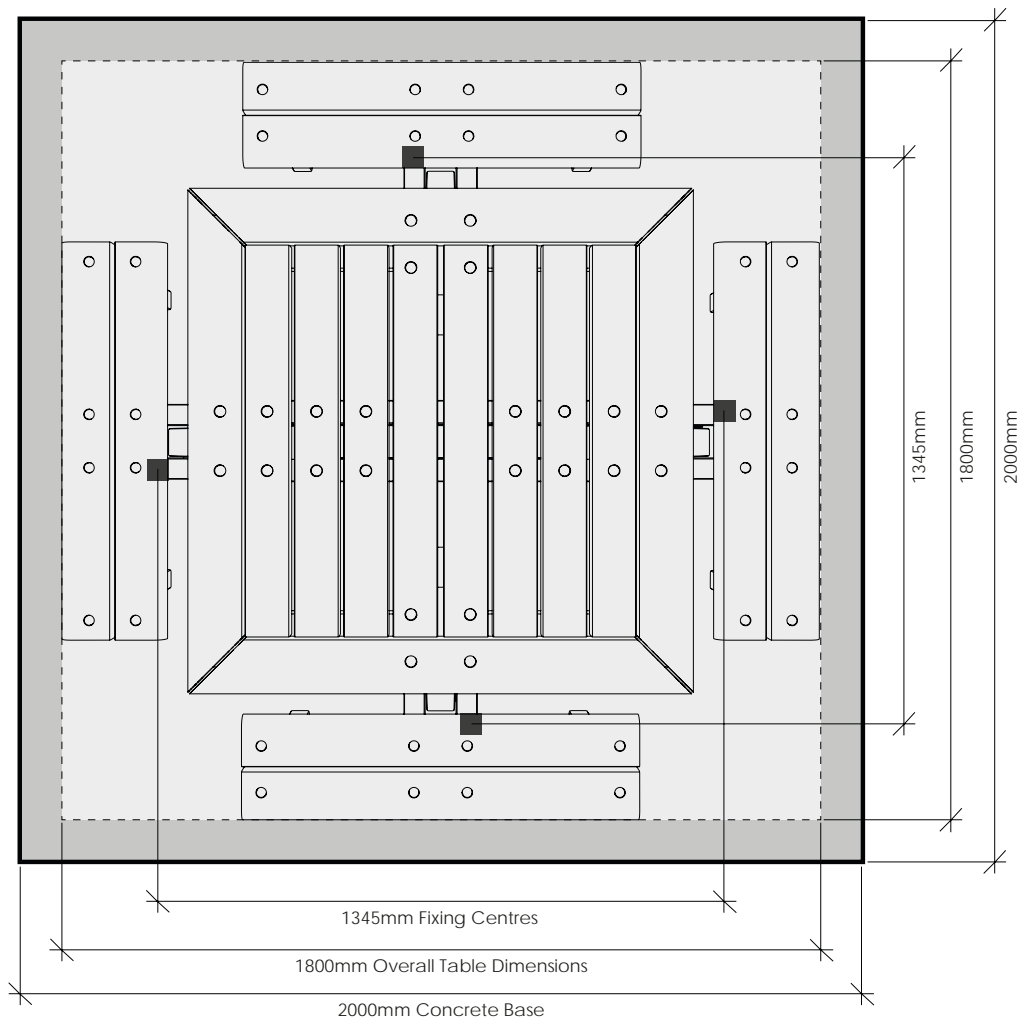



# VIEW B - WHEELCHAIR ACCESS MODEL

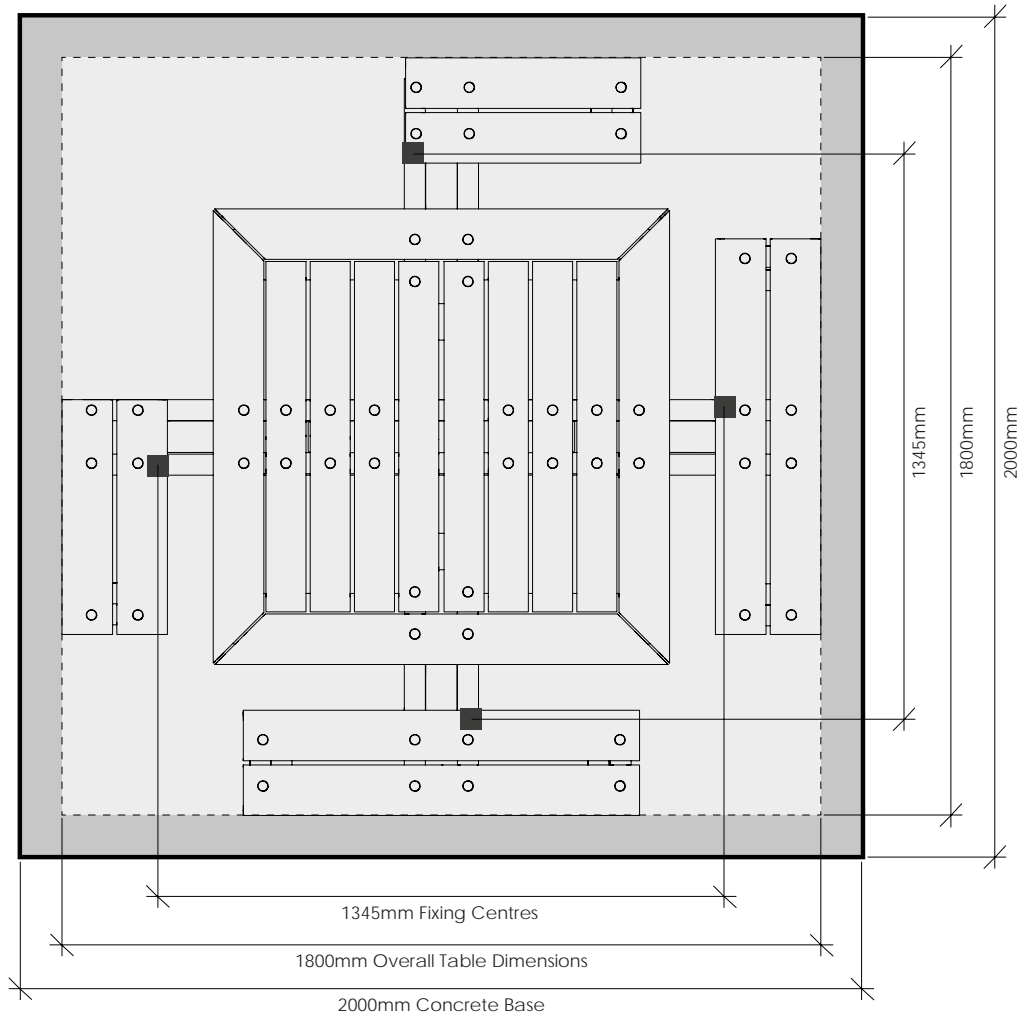

**For optimum fixing performance the following procedure is recommended.**

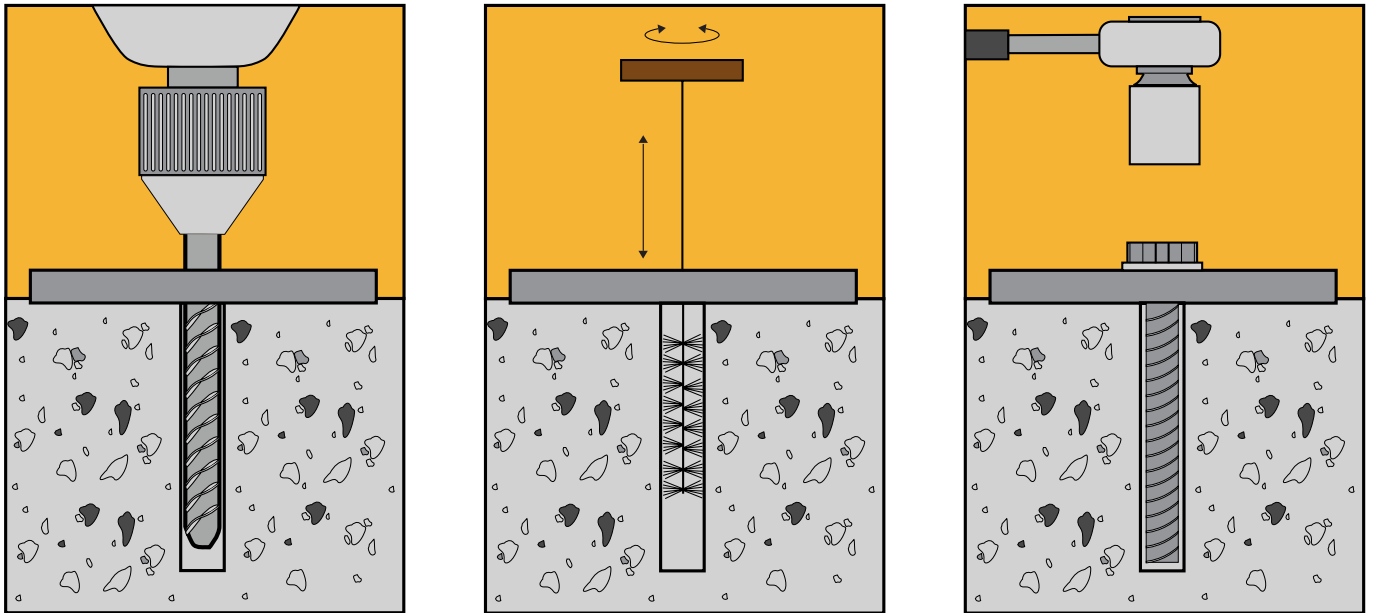

The base should be flat, steel float finished, level and square and preferably be raised slightly above the surrounding ground level.

The concrete base should be a minimum 25N/20mm mix strength equivalent of BS. 5328, Section 2, Part 10, Grade C25.

Using the supplied unit as a template, drill through all 4 (see detail view A) base fixing positions in each of the feet with a 10mm masonry drill to a minimum depth of 120mm.

Clean drill hole thoroughly using a spiral brush and remove all dust using a blow out pump, airline or similar.

Insert the self tapping anchor bolts (ITEM 10) and washer (ITEM 11) into the drilled hole and tighten with socket and wrench set.

**BLANK PAGE**

IMPORTANT NOTE: PLEASE ENSURE THAT ALL RELEVANT PERSONNEL READ THE POINTS LISTED WITHIN THIS LEAFLET AND THAT A COPY IS GIVEN TO STAFF INVOLVED WITH THE INSTALLATION AND MAINTENANCE OF THIS PRODUCT.  
SAFETY NOTE: PLEASE REFER TO 'THE MANUAL HANDLING OPERATIONS REGULATIONS 1992' DURING HANDLING.

 **Glasdon** AND PEMBRIDGE ARE TRADEMARKS OR REGISTERED TRADEMARKS OF GLASDON GROUP OR ITS SUBSIDIARIES IN THE U.K. AND OTHER COUNTRIES

A planned maintenance schedule or regular inspection is recommended, replacing components as necessary.

Replacement components are available direct from GLASDON.

GLASDON cannot be held responsible for claims arising from incorrect installation, unauthorised modifications or misuse of the product.

Issue 4- June 2021 - Stock No. C000/0520 - DWG No. 09B-048-33

© Copyright NOVEMBER 2018

Glasdon UK Ltd reserve the right to alter specifications without prior notice.

 **Glasdon**<sup>®</sup>  
**Glasdon U.K. Limited**  
Preston New Road  
BLACKPOOL  
Lancashire  
FY4 4UL  
Tel: (01253) 600410  
Fax: (01253) 792558  
e-mail: [sales@glasdon-uk.co.uk](mailto:sales@glasdon-uk.co.uk)  
web: [www.glasdon.com](http://www.glasdon.com)