

MODEL SPECIFICATION

REBOUND SIGNMASTER™ BOLLARD

(WITH CONCRETE-IN, IP67 RATED, L.E.D. BASE-LIGHT BOX)

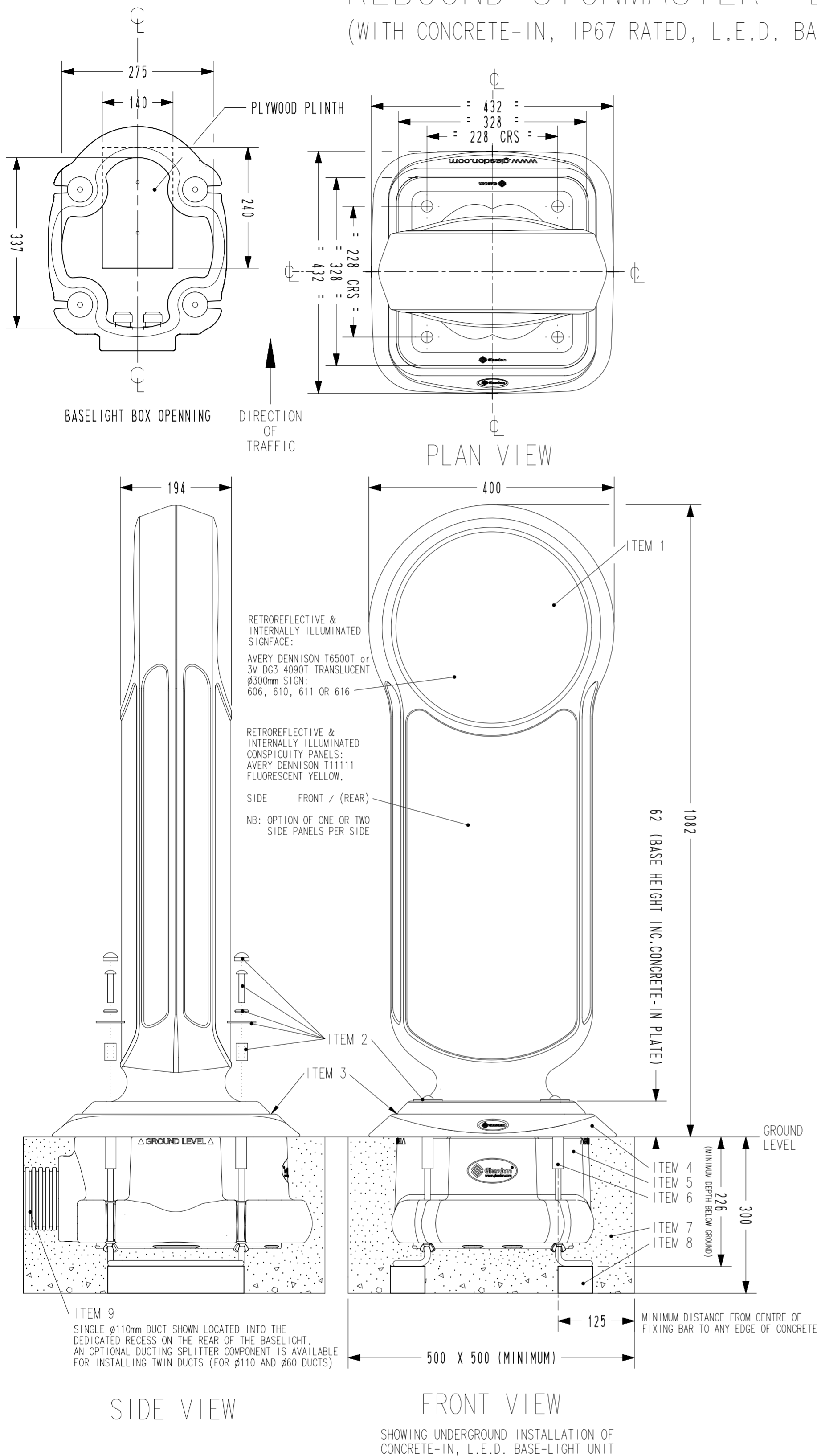

PRODUCT INFORMATION:

- WEIGHT - BOLLARD - 6.0 Kg
BASELIGHT UNIT - 5.8 Kg
FIXINGS - 1.0 Kg
TOTAL - 12.8 Kg
- MATERIAL - BOLLARD: - IMPACTAPOL®
BASELIGHT: - DURAPOL®
FIXINGS: - SCREWS & WASHERS - STAINLESS STEEL
- SPACERS - RIGID PVC
- CONCRETE-IN ANCHOR FIXING BARS - MS BZP
- BOLLARD COLOUR - WHITE
- DIMENSIONS - ALL DIMENSIONS IN mm UNLESS OTHERWISE STATED

INSTALLATION GUIDE:

- ITEM 1 - REMOVABLE BOLLARD - x1
- ITEM 2 - FIXINGS FOR BOLLARD:
 - M10 SCREW COVER CAP & RETAINER WASHER - WHITE NY66 - x4
 - M10 x 50mm SOCKET HEAD SCREW - S/S - x4
 - M10 x Ø50 x 3mm WASHER - POWDER COATED S/S - x4
 - M10 x Ø19 x 28mm SPACER - RIGID PVC - x4
- ITEM 3 - ANTI TRAFFIC FILM GASKET (ADHERED TO BASELIGHT TOP)
- ITEM 4 - 24V OR 230V AC SEALED L.E.D. BASELIGHT TOP C/W LEAD & PLUG
- ITEM 5 - CONCRETE-IN BASELIGHT BOX (MAIN UNIT)
- ITEM 6 - CONCRETE-IN ANCHOR FIXING BAR (2 OFF)
- ITEM 7 - QUICK SETTING CONCRETE (eg. GRADE QC10)
- ITEM 8 - SUPPORT BLOCKS (TO ENSURE ASSEMBLY IS LEVEL)
- ITEM 9 - STANDARD Ø110mm CABLE DUCT 'RIGIDUCT' (ORANGE FOR LIGHTING)
- ORIENTATE SIGNFACE TOWARDS ONCOMING TRAFFIC.
- WE RECOMMEND THE USE OF OUR OPTIONAL 'INSTALLATION PLATE' FOR CONCRETING INTO THE GROUND. THIS IS TO BE FIXED TO THE TOP OF THE PLATE (ITEM 4) IN-LINE WITH THE 'CONCRETE-IN FIXING BARS' (ITEM 3). THIS PREVENTS EXCESS CONCRETE ENCRUACHING INTO THE ASSEMBLY, PROVIDES AN EDGE TO TROWEL UP TO AND ENSURES FIXING CENTRES ARE CORRECT ONCE CONCRETE HAS SET.

RECOMMENDED MINIMUM HOLE SIZE: 500x500x300mm DEEP.

FOR SPEED WE RECOMMEND INSTALLING WITH QUICK SETTING CONCRETE (eg. GRADE QC10) BUT EXACT INSTALLATION REQUIREMENTS SHOULD BE ASSESSED FROM A SITE SURVEY.

- AVOID CONTACT WITH HOT TARMACADAM AS THIS WILL SERIOUSLY IMPAIR THE PERFORMANCE OF THE BOLLARD.

OPTIONAL PARTS:

- OPTIONS AVAILABLE FOR THE PRODUCT:
 - DUCTING SPLITTER - FOR A CLEAN INSTALLATION OF TWO DUCTS TO THE BACK OF THE BASELIGHT BOX (CATERS FOR BOTH STANDARD Ø110mm & Ø60mm DUCTS)
 - DUCTING CHAMBER - CLIPS TO THE BOTTOM OF THE BASELIGHT BOX AND INCLUDES 'KNOCK-OUTS' ALL ROUND FOR BOTH STANDARD Ø110mm & Ø60mm DUCTS. ONE DUCTING CHAMBER ASSEMBLED GIVES A FOUNDATION DEPTH OF 450mm, AND TWO STACKED TOGETHER GIVES A FOUNDATION DEPTH OF 750mm.
 - INSTALLATION PLATE (HIGHLY RECOMMENDED)
 - 230V AC TO 24V AC TRANSFORMER - C008/3042
 - BODY C/W FRONT, 1xLH & 1xRH CONSPICUITY PANELS
 - BODY C/W FRONT, 2xLH & 2xRH CONSPICUITY PANELS
 - BODY C/W FRONT, REAR, 2xLH & 2xRH CONSPICUITY PANELS
 - + A RANGE OF AUTHORISED SIGNFACES &/OR WHITE DISC
- SPARES ARE AVAILABLE, WHICH INCLUDE:
 - BOLLARD C/W FIXINGS & RETROREFLECTIVE PATCHES
 - BOLLARD ONLY
 - RANGE OF SIGNFACES
 - FIXINGS
 - 24V OR 230V AC SEALED L.E.D. BASELIGHT TOP UNIT C/W LEAD & PLUG
 - 230V AC TO 24V AC TRANSFORMER - C008/3042

TECHNICAL DATA:

- SURFACE AREA OF CONSPICUITY PANELS:
 - FRONT = 161,701mm² (PROJECTED)
 - SINGLE SIDE = 24,255mm²
 - OPTIONAL DOUBLE SIDE = 48,510mm²
- SURFACE AREA OF SIGNFACE = 70,686mm²
- ALL RETROREFLECTIVE MATERIALS SUPPLIED BY GLASDON ARE AS RECOMMENDED IN TABLE NA1 OF THE NATIONAL ANNEX OF BS EN 12899-1: 2007 FIXED VERTICAL ROAD SIGNS.
- MICROPRISMATIC RETROREFLECTIVE MATERIALS USED ON OUR PRODUCTS MEET THE REQUIREMENTS OF BS 8408 2005 ROAD TRAFFIC SIGNS. TESTING AND PERFORMANCE OF MICROPRISMATIC RETROREFLECTIVE SHEETING MATERIALS WHEN SITED NORMALLY AND USED IN THEIR NORMAL APPLICATION.
- SEALED L.E.D. BASELIGHT UNIT c/w PHOTOCCELL:
 - 24V AC - TOTAL 'ON' POWER USE: 6.5 WATTS (REQUIRES TRANSFORMER C008/3042)
 - 230V AC - TOTAL 'ON' POWER USE: 5.0 WATTS
- NOTE: IF USING A 24V ac BASELIGHT UNIT ON A 230V ac SYSTEM, UNIT REQUIRES TRANSFORMER C008/3042 WHICH IS AVAILABLE FROM GLASDON. THIS CAN POWER UP TO 3x L.E.D. BASELIGHTS. (SEE MODEL SPEC DRAWING 02S070-S01).

ADDITIONAL CONNECTIONS: WE RECOMMEND THE USE OF IP68 RATED SEALED COMPONENTS

- | | | | |
|-----------|---------------------------------------|---|---------------------------------------|
| ● 230v ac | TOTAL 'ON' POWER USE - 5.0 WATTS | 24v ac (REQUIRES TRANSFORMER C008/3042) | TOTAL 'ON' POWER USE - 6.5 WATTS |
| | STANDBY POWER USE - 0.33 WATTS | | STANDBY POWER USE - 1.5 WATTS |
| | UMSUG CODE 'ON' - 40 0005 0012 100 | | UMSUG CODE 'ON' - 40 0005 0000 100 |
| | UMSUG CODE STANDBY - 96 0001 0003 100 | | UMSUG CODE STANDBY - 96 0002 0000 100 |
| | POWER FACTOR - 0.91 | | POWER FACTOR - 0.48 |

PERSPECTIVE VIEW OF STANDARD BASELIGHT WITHOUT BOLLARD ATTACHED

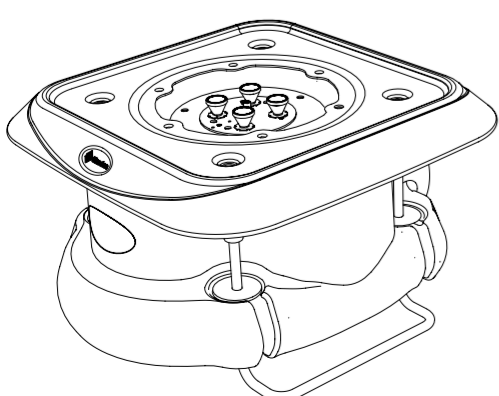

PERSPECTIVE VIEWS OF BASELIGHT WITH OPTIONAL DUCTING CHAMBER (1) & OPTIONAL DUCTING SPLITTER (2) ATTACHED

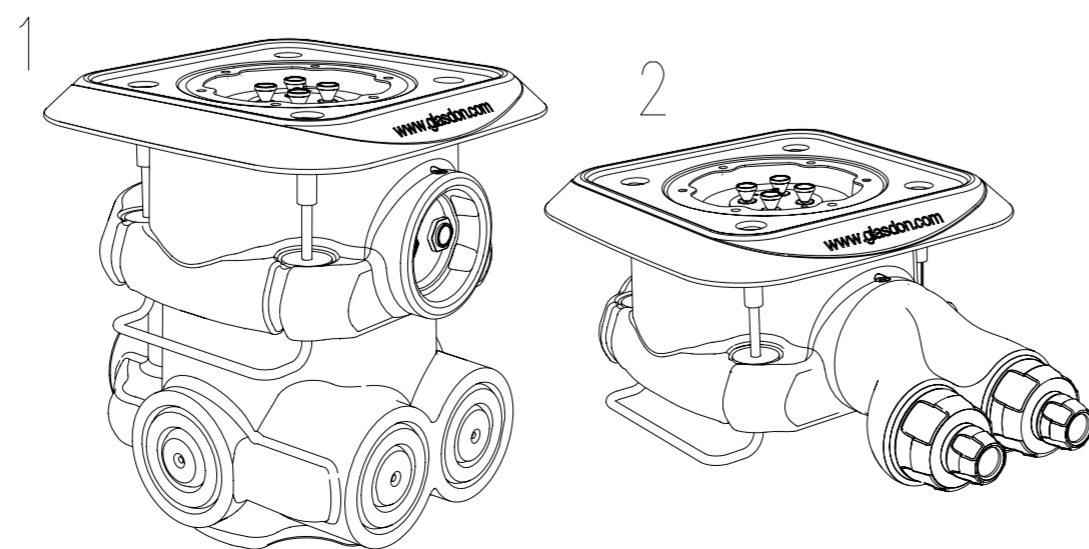

Web site: www.glasdon.com
E-mail: sales@glasdon.com
Telephone: 01253 600400
Facsimile: 01253 792558

Copyright and/or design right in this representation and the product it depicts is reserved by Glasdon Group Limited. The issue of this drawing, is a confidential disclosure of its contents, and is made on condition that it is neither disclosed to a third party, nor any item described here in and designed by Glasdon Group Limited, is produced either in whole or in part without the written consent of Glasdon Group Limited.

SPECIFICATION NUMBER-02S073-S02 | ISSUE 04

©GLASDON GROUP LTD 11/02/10 | SHEET SIZE:A2