

MODEL SPECIFICATION

SOCKETED REBOUND SIGNMASTER™ BOLLARD C/W SOCKET

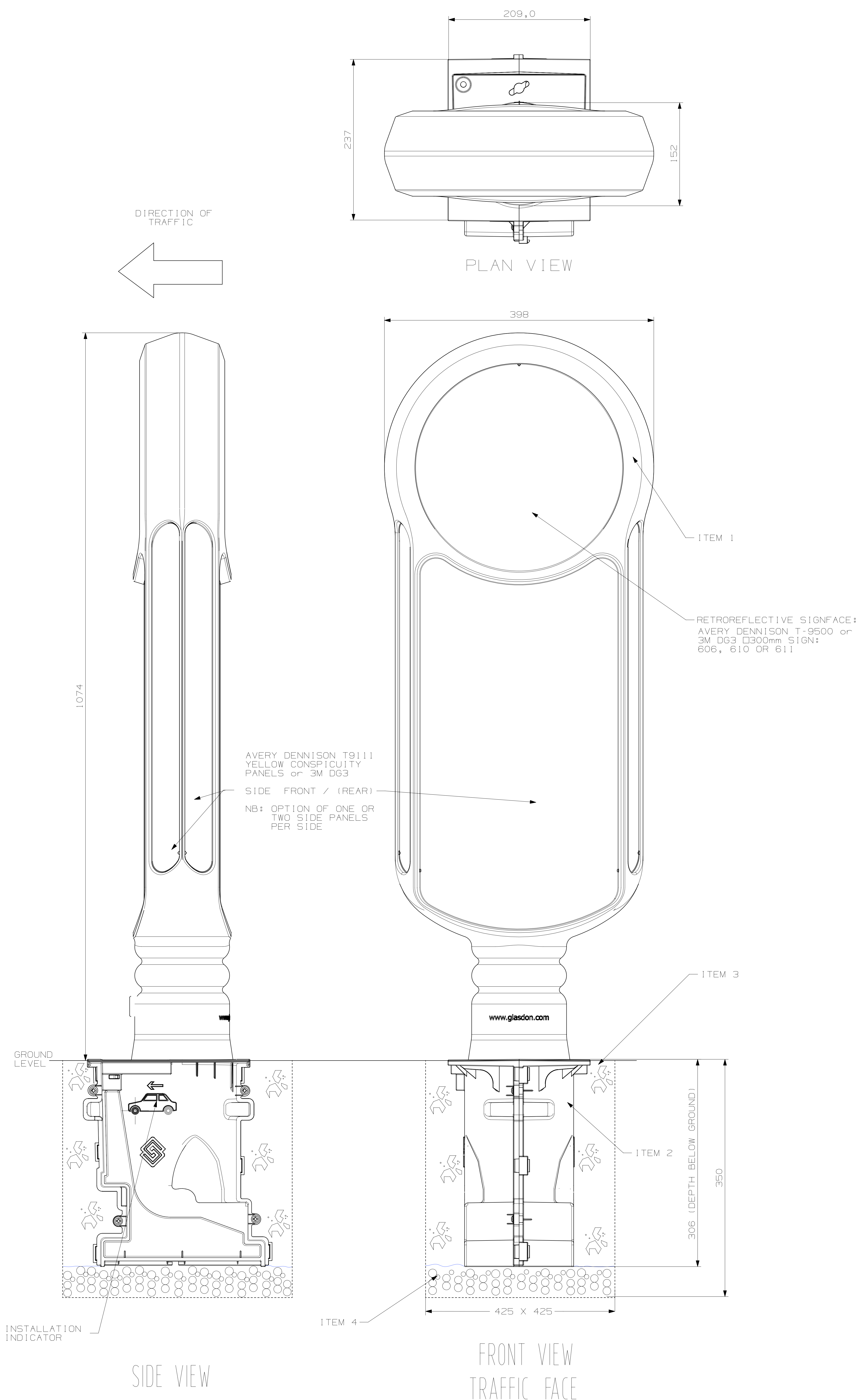

PRODUCT INFORMATION :

- WEIGHT - BOLLARD - 5.5 Kg
SOCKET - 1.4 Kg
TOTAL - 6.9Kg
- MATERIAL - BOLLARD: - IMPACTAPOL®
SOCKET: - DURAPOL
FIXINGS: - SCREWS - STAINLESS STEEL
- WASHERS - STAINLESS STEEL
- ANCHOR - RIGID PVC
- BODY COLOURS - BLACK / WHITE
- DIMENSIONS - ALL DIMENSIONS IN MM UNLESS OTHERWISE STATED.

INSTALLATION GUIDE :

- ITEM 1 - REMOVABLE BOLLARD
- ITEM 2 - CONCRETE-IN SOCKET
- ITEM 3 - CONCRETE - TO REDUCE TIME ON SITE WE RECOMMEND USING QUICK SETTING CONCRETE (eg. GRADE QC10)
- ITEM 4 - GRAVEL
- ENSURE THAT ANY SIGNFACE FACES TOWARDS ONCOMING TRAFFIC.
- RECOMMENDED HOLE SIZE 425 X 425 X 350MM DEEP.
- WE RECOMMEND THE SOCKET IS BEDDED ON GRAVEL FOR DRAINAGE.
- COVER SOCKET TO AVOID BUILD UP OF CONCRETE/GRAVEL FALLING IN WHICH WILL PREVENT BOLLARD SEATING AND LOCKING.
- EXACT INSTALLATION REQUIREMENTS SHOULD BE ASSESSED FROM A SITE SURVEY.
- AVOID CONTACT WITH HOT TARMACADAM AS THIS WILL SERIOUSLY IMPAIR THE PERFORMANCE OF THE BOLLARD AND SOCKET.

OPTIONS AVAILABLE FOR THE PRODUCT :

- BODY C/W FRONT, 1xLH & 1xRH CONSPICUITY PANELS
- BODY C/W FRONT, 2xLH & 2xRH CONSPICUITY PANELS
- BODY C/W FRONT, REAR, 2xLH & 2xRH CONSPICUITY PANELS
- + A RANGE OF AUTHORISED SIGNFACES &/OR WHITE DISC
- INSTALLATION PLATE

- SPARES ARE AVAILABLE, WHICH INCLUDE:
 - BOLLARD C/W RETROREFLECTIVE PATCHES
 - RANGE OF SIGNFACES
 - KEY

● SURFACE AREA OF CONSPICUITY PANELS:

- FRONT = 151,475mm (PROJECTED)
- SINGLE SIDE = 20,784mm
- OPTIONAL DOUBLE SIDE = 41,568mm

● SURFACE AREA OF SIGNFACE = 71,314mm

- ALL RETROREFLECTIVE MATERIALS SUPPLIED BY GLASDON UK ARE AS RECOMMENDED IN TABLE NA1 OF THE NATIONAL ANNEX OF BS EN 12899-1 2007 FIXED VERTICAL ROAD SIGNS.

MICROPRISMATIC RETROREFLECTIVE MATERIALS USED ON OUR PRODUCTS MEET THE REQUIREMENTS OF BS 8408 2005 ROAD TRAFFIC SIGNS. TESTING AND PERFORMANCE OF MICROPRISMATIC RETROREFLECTIVE SHEETING MATERIALS WHEN SITED NORMALLY AND USED FOR THEIR NORMAL APPLICATION.



website: www.glasdon.com
e-mail: sales@glasdon.com
Telephone: 01253 600400
Facsimile: 01253 792558

Copyright and/or design right in this representation and the product it depicts is reserved by Glasdon Group Limited. The issue of this drawing, is a confidential disclosure of its contents, and is made on condition that it is neither disclosed to a third party, nor any item described here in and designed by Glasdon Group Limited, is produced either in whole or in part without the written consent of Glasdon Group Limited.

SPECIFICATION NUMBER - 025075-S01

ISSUE 01

GLASDON GROUP LTD 13/09/12

SHEET SIZE:A2