

# MODEL SPECIFICATION

## NEOPOLITAN™ DELINEATOR - SURFACE MOUNTED

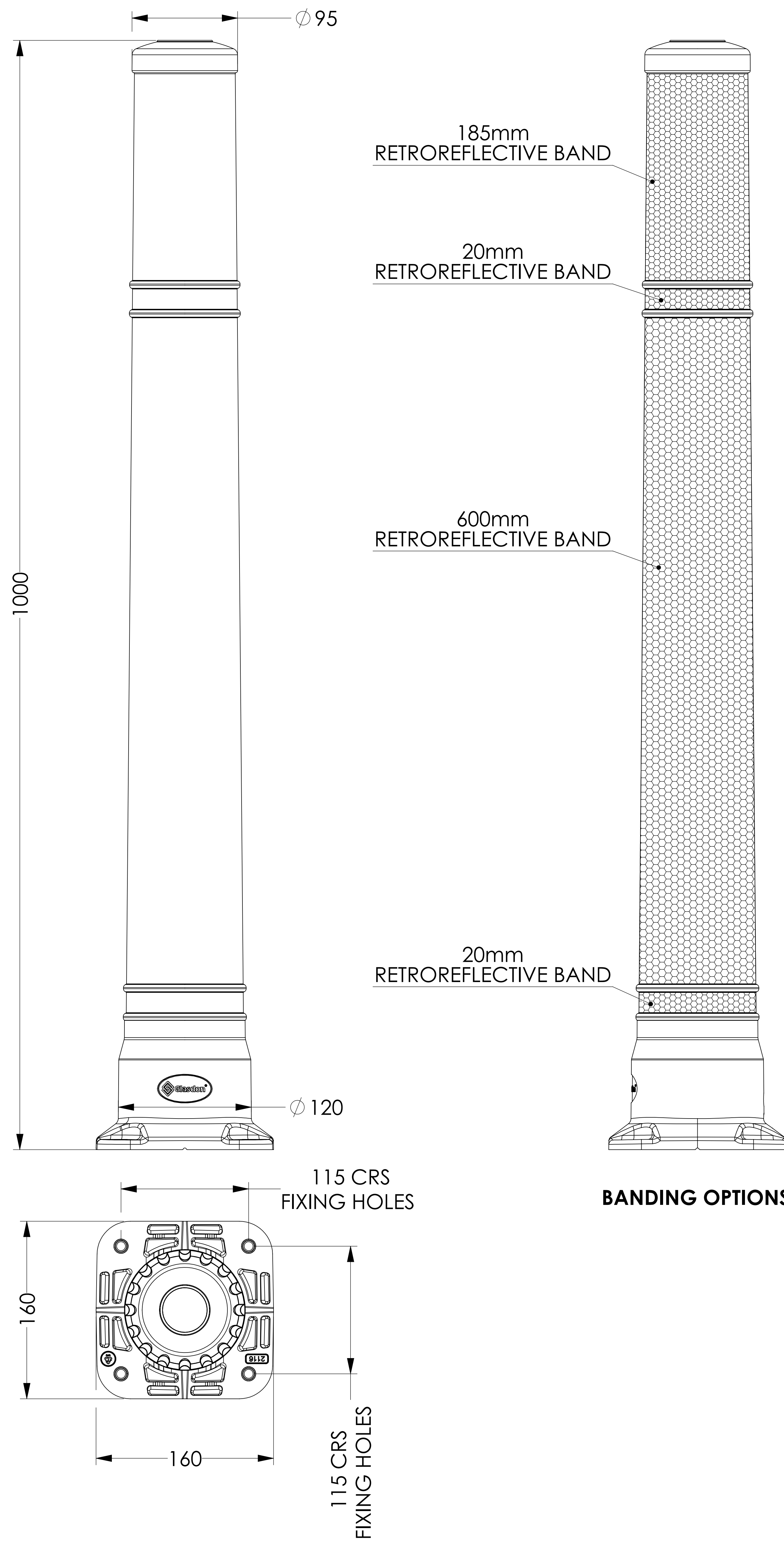

### PRODUCT INFORMATION:

#### DESCRIPTION

REBOUNDABLE POST FOR DELINEATING TRAFFIC.

#### MATERIAL

DELINEATOR POST: REFLEXAPOL®

GROUND FIXINGS: MILD STEEL BZP COATING

RETROREFLECTIVE BANDS: 3M - 3310 SERIES

#### DIMENSIONS

ALL DIMENSIONS IN mm UNLESS OTHERWISE STATED.

#### COLOURS

- RED  
- BLACK

#### WEIGHTS

DELINEATOR POST: 1.92kg

GROUND FIXINGS: 0.4kg

#### BANDING OPTIONS

- 600mm RETROREFLECTIVE BAND (WHITE)
- 185mm RETROREFLECTIVE BAND (WHITE)
- 20mm RETROREFLECTIVE BAND - TOP (WHITE)
- 185 & 20mm RETROREFLECTIVE BAND - TOP / BOTTOM (WHITE)
- 2 x 20mm RETROREFLECTIVE BAND - TOP / BOTTOM (WHITE)

### INSTALLATION INSTRUCTIONS:

- ITEM 1 - DELINEATOR POST
- ITEM 2 - SELF-TAPPING GROUND ANCHOR - M10 x 100mm
- ITEM 3 - WASHER - M12 x 28mm

- KEEP A MINIMUM DISTANCE OF 100mm FROM ANY EDGE OF CONCRETE OR TARMAC BASE.
- PLACE POST IN DESIRED POSITION / ORIENTATION.
- USING THE FIXING HOLES AS A GUIDE, DRILL 4 HOLES (Ø 10mm x 120mm (MINIMUM DEPTH))
- USING A 17mm SOCKET WRENCH, FIX THE POST DOWN USING THE SELF-TAPPING GROUND ANCHORS AND WASHERS. (4 OFF)
- DO NOT OVER TIGHTEN THE GROUND ANCHORS. TIGHTEN BY NO MORE THAN 1/4 TURN. (MAXIMUM TORQUE IN CONCRETE - 60Nm)

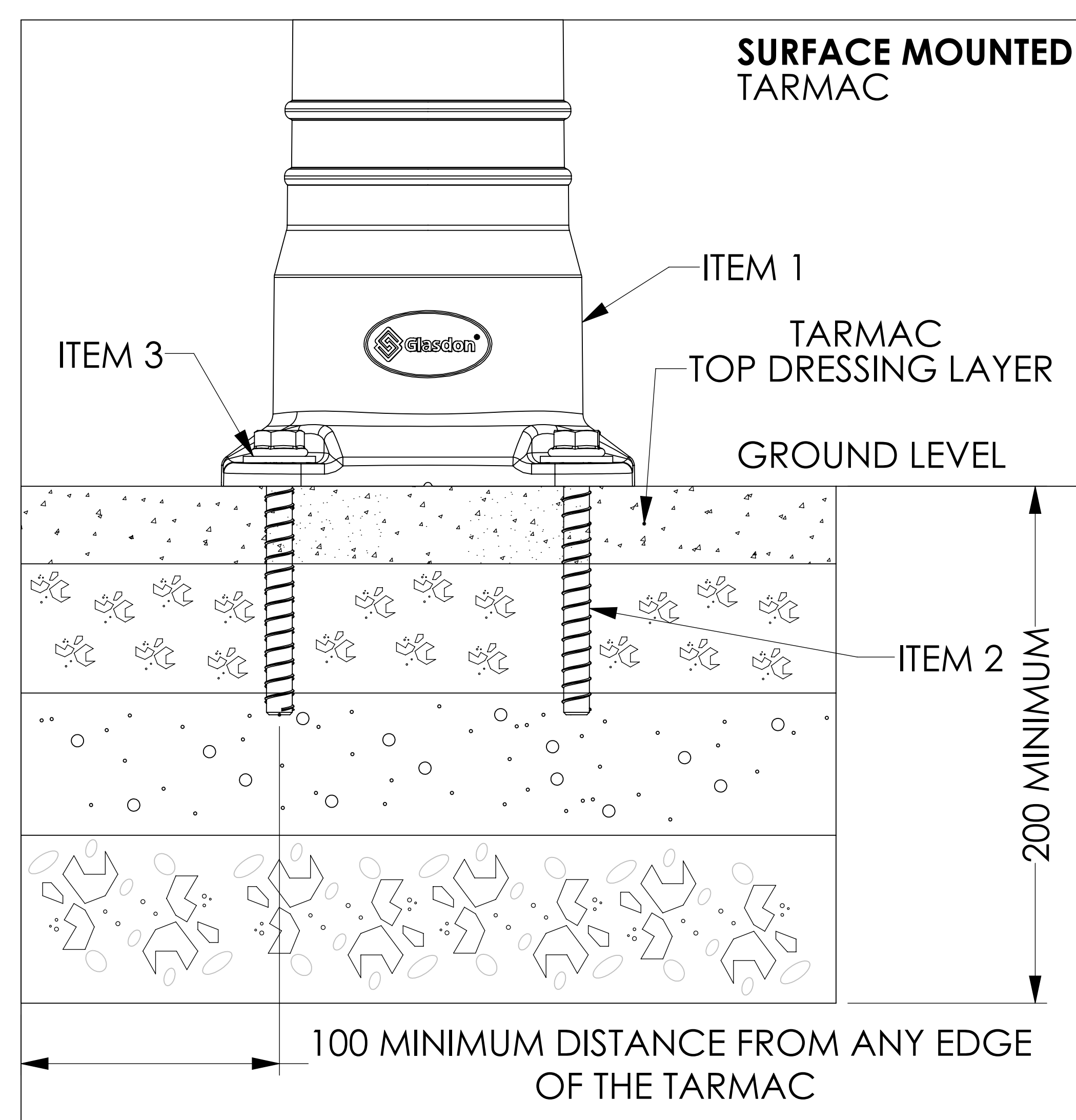
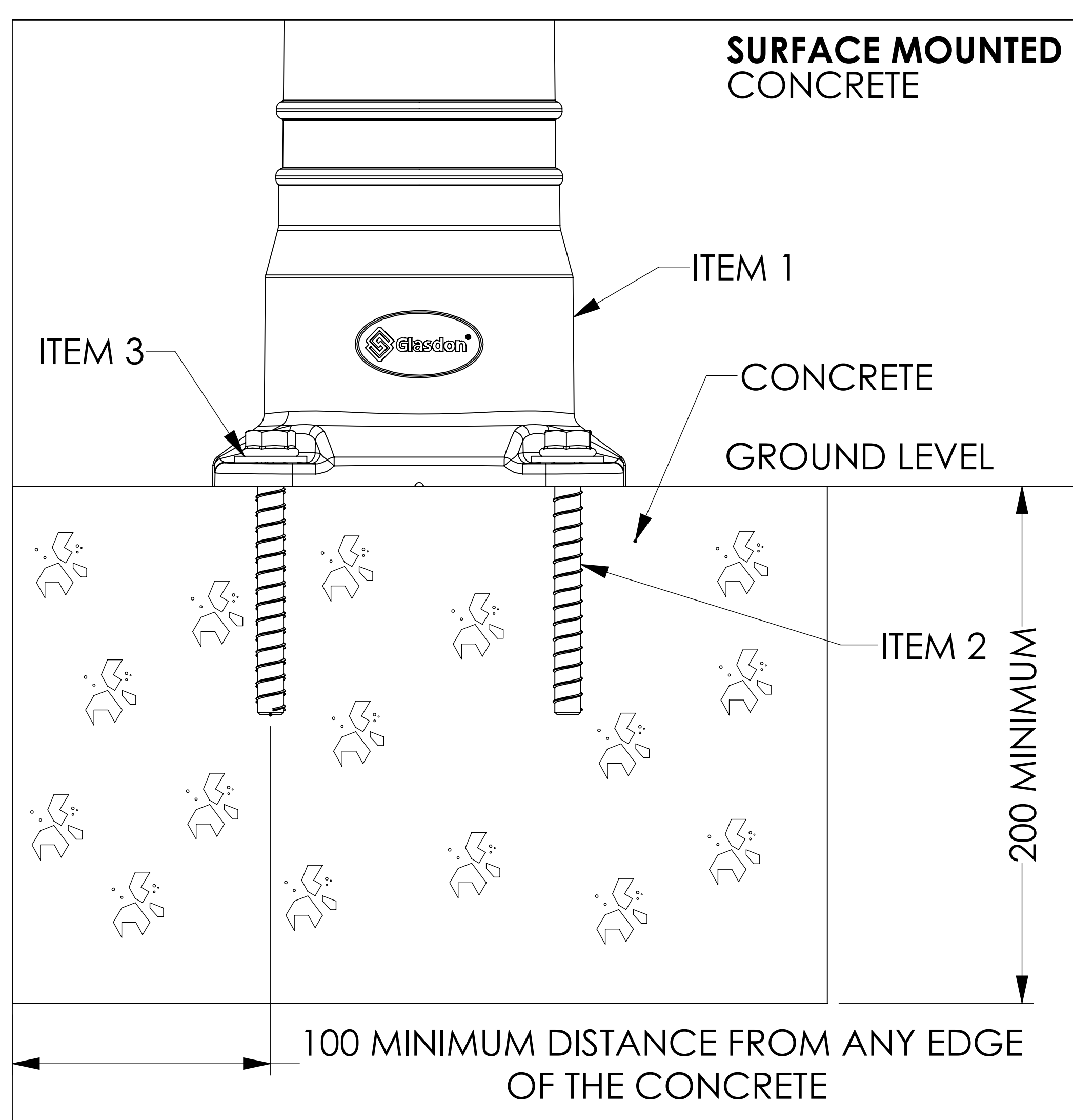

Website: [www.glasdon.com](http://www.glasdon.com)  
Email: [sales@glasdon.com](mailto:sales@glasdon.com)  
Telephone: 01253 600 400  
Facsimile: 01253 732558

Copyright of this dwg. is reserved by Glasdon Group. The issue of this dwg. is a confidential disclosure of its contents, and is made on condition that it is neither disclosed to a third party, nor any item described herein and designed by Glasdon Group, is produced either in whole or in part without the prior written consent of Glasdon Group.

SPECIFICATION NUMBER - 02S090-S08

ISSUE 01

GLASDON GROUP LTD 16/03/22

SHEET SIZE : A0