

# MODEL SPECIFICATION ADMIRAL™ BOLLARD – SOCKETED

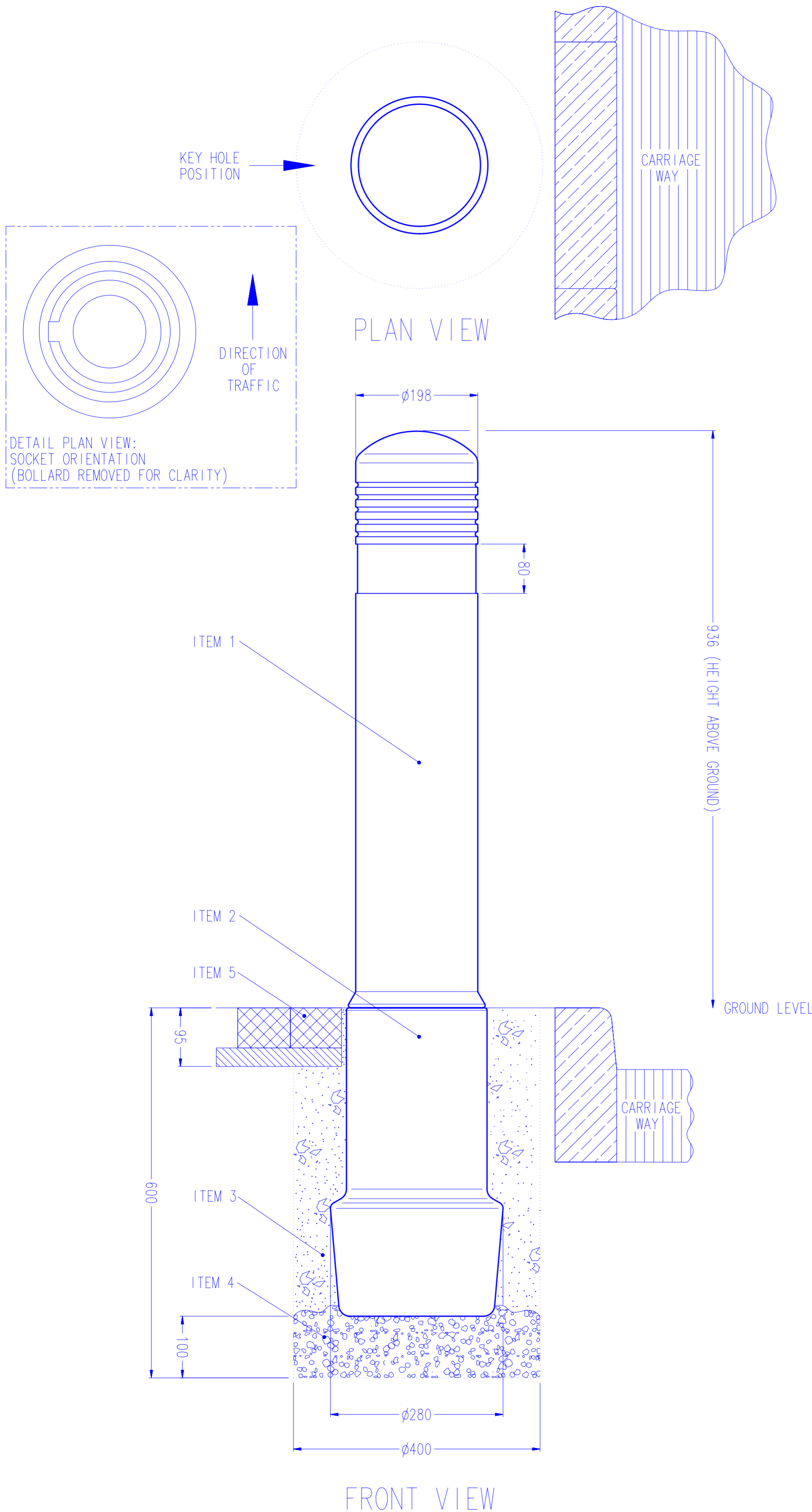

## PRODUCT INFORMATION:

- WEIGHT - BOLLARD 5.1 Kg  
SOCKET 3.8 Kg  
TOTAL 8.9 Kg
- MATERIAL - DURAPOL®
- COLOURS - MILLSTONE, SANDSTONE, WHITE, BLACK, GREY AND STONE.
- DIMENSIONS - ALL DIMENSIONS IN MM UNLESS OTHERWISE STATED.

## INSTALLATION GUIDE:

- ITEM 1 - REMOVABLE BOLLARD COMPLETE WITH LOCKING MECHANISM
- ITEM 2 - PERMANENT GROUND SOCKET
- ITEM 3 - QUICK SETTING CONCRETE (eg. GRADE QC10)
- ITEM 4 - GRAVEL
- ITEM 5 - BLOCK PAVING
- FOR SAFETY SITE KEY HOLE ON OPPOSITE SIDE TO TRAFFIC (SEE DETAIL PLAN VIEW FOR CORRECT SOCKET ORIENTATION).
- ENSURE REFLECTIVE BANDING IS IN THE CORRECT ORIENTATION - RED TOWARDS ONCOMING TRAFFIC (YELLOW ON CENTRAL RESERVATION).
- RECOMMENDED HOLE SIZE  $\phi 400\text{mm}$  x 600mm DEEP.
- WE RECOMMEND THE SOCKET IS BEDDED ON GRAVEL FOR DRAINAGE.
- COVER SOCKET TO AVOID BUILD UP OF CONCRETE/GRAVEL IN SOCKET, WHICH WILL PREVENT BOLLARD FROM SEATING AND LOCKING.
- AVOID CONTACT WITH HOT TARMACADAM AS THIS WILL SERIOUSLY IMPAIR THE PERFORMANCE OF THE BOLLARD.
- WE RECOMMEND INSTALLING WITH QUICK SETTING CONCRETE (eg. GRADE QC10) BUT EXACT INSTALLATION REQUIREMENTS SHOULD BE ASSESSED FROM A SITE SURVEY.

## OPTIONAL PARTS:

- PEDESTRIAN SAFETY. A LOCKING BLANKING CAP IS AVAILABLE TO COVER THE SOCKET WHEN THE BOLLARD IS REMOVED.
- ADDITIONAL SECURITY. A KEY HOLE PLUG MAY BE FITTED TO THE BOLLARD TO HELP PREVENT UNAUTHORISED REMOVAL OF THE BOLLARD.
- ALUMINIUM BACKED RETROREFLECTIVE BANDING (TO BS EN 12899-1:2007, FIXED, VERTICAL ROAD TRAFFIC SIGNS) OR DECORATIVE BANDING MAY BE FITTED.
- STANDARD BANDING SETS:  
1 x 80mm BAND.
- STANDARD OR SPIKED CHAIN LINKAGE IS AVAILABLE. RECOMMENDED PITCH BETWEEN BOLLARDS 1.1m.
- SPARE BOLLARDS, SOCKETS, KEYS AND BANDING ARE AVAILABLE.
- ALL RETOREFLECTIVE MATERIALS SUPPLIED BY GLASDON ARE AS RECOMMENDED IN TABLE NA1 OF THE NATIONAL ANNEX OF BS EN 12899-1 2007 FIXED VERTICAL ROAD SIGNS.



website: [www.glasdon.com](http://www.glasdon.com)  
 e-mail: [sales@glasdon.com](mailto:sales@glasdon.com)  
 Telephone: 01253 600400  
 Facsimile: 01253 792558

Copyright and/or design right in this representation and the product it depicts is reserved by Glasdon Group Limited. The issue of this drawing, is a confidential disclosure of its contents, and is made on condition that it is neither disclosed to a third party, nor any item described here in and designed by Glasdon Group Limited, is produced either in whole or in part without the written consent of Glasdon Group Limited.

SPECIFICATION NUMBER - 075108-501

ISSUE 07

GLASDON GROUP LTD 18/02/15

SHEET SIZE+A2