

MODEL SPECIFICATION

ADMIRAL™ REBOUND™ BOLLARD

(ADMIRAL MK III CONCRETED IN TO EXISTING MK I SOCKET)

PRODUCT INFORMATION:

- WEIGHT - BOLLARD & SOCKET 6.6Kg
- MATERIAL - IMPACTAPOL®
- COLOURS - WHITE AND BLACK
- DIMENSIONS - ALL DIMENSIONS IN MM UNLESS OTHERWISE STATED.
- ITEM 1 - BOLLARD
- ITEM 2 - BLOCK PAVING
- ITEM 3 - QUICK SETTING CONCRETE (eg. GRADE QC10)
- ITEM 4 - EXISTING SOCKET

TECHNICAL REFERENCE:

- COMPLIES WITH THE 'DEPARTMENT OF TRANSPORT TRAFFIC SIGNS MANUAL, CHAPTER 4, WARNING SIGNS, 2004.'

INSTALLATION GUIDE:

- ENSURE REFLECTIVE BANDING IS IN THE CORRECT ORIENTATION. RED REFLECTOR FACES ONCOMING TRAFFIC ON THE NEAR-SIDE. WHITE REFLECTOR FACES ONCOMING TRAFFIC ON THE OFF-SIDE.
- ENSURE SOCKET IS SECURED SECURELY IN THE GROUND - RECOMMENDED HOLE SIZE $\phi 400\text{mm}$ x 475mm DEEP
- AVOID CONTACT WITH HOT TARMACADAM AS THIS WILL SERIOUSLY IMPAIR THE PERFORMANCE OF THE BOLLARD.
- WE RECOMMEND INSTALLING WITH QUICK SETTING CONCRETE (eg. GRADE QC10), BUT EXACT INSTALLATION REQUIREMENTS SHOULD BE ASSESSED FROM A SITE SURVEY.

BOLLARD INSTALLATION NOTES -

- (1) ENSURE EXISTING SOCKET IS FILLED 100mm FROM THE TOP OF THE SOCKET WITH A SAND & CONCRETE MIX. AN AGGREGATE MIX WILL PREVENT THE BOLLARD FROM BEING INSERTED FULLY.
 - (2) THE ADMIRAL REBOUND BOLLARD™ (ANCHOR BASE) IS INSERTED INTO THE SOCKET IN THE CORRECT ORIENTATION AND TWISTED INTO POSITION.
 - (3) ENSURE THE BOLLARD IS FULLY INSERTED INTO THE SOCKET & CONCRETE IS ALLOWED SUFFICIENT TIME TO SET.
- SUITABLE FOR HARD AND SOFT GROUND.

OPTIONAL PARTS:

- IMPACTALIGHT REBOUND RETROREFLECTIVE BANDING (TO BS EN 12899-1:2001. FIXED, VERTICAL ROAD TRAFFIC SIGNS) OR DECORATIVE BANDING MAY BE FITTED.
- STANDARD BANDING SETS: 1 x 150mm BAND.
- ALL RETROREFLECTIVE MATERIALS SUPPLIED BY GLASDON ARE AS RECOMMENDED IN TABLE NA1 OF THE NATIONAL ANNEX OF BS EN 12899-1 2007 FIXED VERTICAL ROAD SIGNS.

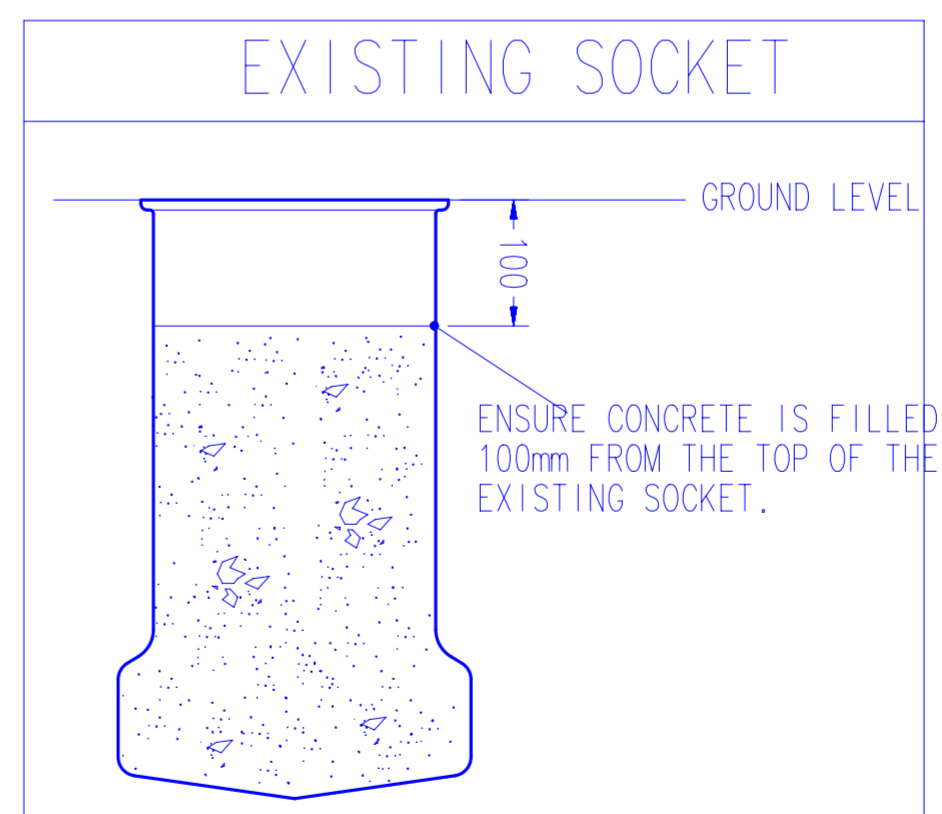
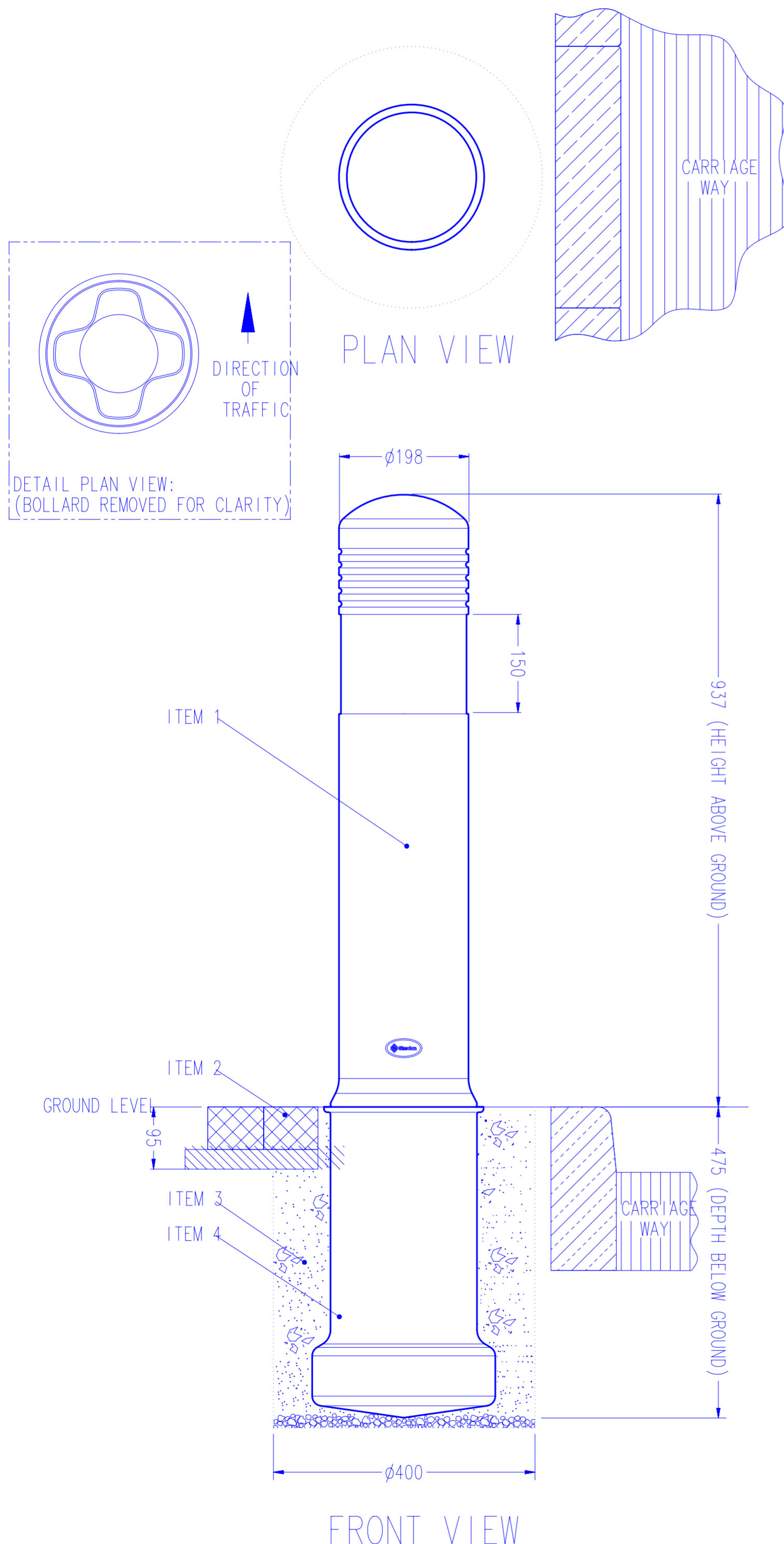

website: www.glasdon.com
 e-mail: sales@glasdon.com
 Telephone: 01253 600400
 Facsimile: 01253 792558

Copyright and/or design right in this representation and the product it depicts is reserved by Glasdon Group Limited. The issue of this drawing, is a confidential disclosure of its contents, and is made on condition that it is neither disclosed to a third party, nor any item described here in and designed by Glasdon Group Limited, is produced either in whole or in part without the written consent of Glasdon Group Limited.

SPECIFICATION NUMBER - 115043-502 ISSUE 07

GLASDON GROUP LTD 18/02/15 SHEET SIZE:A2